

**VALLECITO UNION SCHOOL DISTRICT
BOARD OF TRUSTEES MEETING
AGENDA**

There will be a regular meeting held by the **Vallecito Board of Trustees** at the
District Office Conference Room

December 14, 2016

4:00 p.m. – Open Public Session - Convene to Closed Session

5:30 p.m. Open Public Session

Any writings or documents that are public records and are provided to a majority of the governing board regarding an open session item on this agenda will be made available for public inspection in the District Office located at 4545B Moran Road during normal business hours.

Government Code Section 54954.3 provides that the public will have an opportunity to address the Board on any item described on a regular or special meeting either before or during the consideration of that item. The Board reserves the right to limit the time of presentation by individual and cumulative (BB 9323)

- I. REGULAR MEETING CALLED TO ORDER**
- II. ESTABLISHMENT OF QUORUM** - Board member Carol Gordon may attend Closed Session at the District Office and then on conference call for the regular meeting from the following address: 348 Scott Street, Murphys, CA
- III. APPROVAL OF AGENDA** - Action to add or delete items from any portion of the agenda or to discuss any consent agenda items must be taken prior to adoption of the agenda.
- IV. PUBLIC COMMENT ON ANY ITEM ON THE CLOSED SESSION AGENDA**
- V. CLOSED SESSION**
 - A. PERSONNEL**
 - ADMINISTRATION
 - Public Employee Performance Evaluation – Superintendent
 - B. CONFERENCE WITH LABOR NEGOTIATOR – Donald Ogden – Superintendent**
 - Vallecito Teachers’ Association
- VI. OPEN SESSION**
 - A. Board Report of action, if any, taken during closed session
 - B. Pledge of Allegiance

ANNUAL ORGANIZATIONAL MEETING / ELECTION OF OFFICERS

Education Code Section 35143, the Board of Trustees must hold an annual organizational meeting. The Board will take the following action:

1. Adopt Resolution # 16-17-08 Accept the Canvass of the General Election held on November 8, 2016 – Pg 1
2. Oath of Office for new members
3. Elect a President and a Clerk from its members. The Superintendent will conduct the election for the President, and following the election of the President, will turn the gavel over to the incoming President who will conduct the remainder of the organizational meeting and assume all other responsibilities of the office for the year.
4. Appoint a Secretary to the Board. (*Superintendent*)
5. Authorize signatures for Board related matters. (*Superintendent, Business Manager, Manager of Ops*)
6. Develop a schedule of regular meetings for the year – Pg 10
7. Develop a Board Attention Calendar for the year – Pg 11
8. Designate Board Committee Representatives – Pg 12
9. Thank you and presentation to outgoing members

January 25, 2017, 5:30 p.m. at the District Office

- ❖ Assessor's report
- ❖ Budget Assumptions
- ❖ Governor's Budget Workshop report
- ❖ School Calendars – Site visits
- ❖ Williams Complaint Summary Oct – Dec
- ❖ Personnel
- ❖ SARC Reports

XI. ADJOURNMENT

Posting of notice by December 11, 2016: The Agenda was emailed to the following: Calaveras Enterprise, Union Democrat, The Pine Tree, Calaveras Chronicle and to staff and various other community members. Posted at: District Office and website: vallecito-ca.schoolloop.com

In accordance with the Americans with Disabilities Act, if you need a special accommodation to participate, please contact the Vallecito Union School District Office at 209-795-8500 at least 48 hours in advance.

1 **VALLECITO UNION SCHOOL DISTRICT**

2 Resolution # 16-17-08

3 **RESOLUTION ACCEPTING THE CANVASS OF THE PRESIDENTIAL**
4 **GENERAL ELECTION HELD ON NOVEMBER 4, 2014 PURSUANT TO**
5 **DIVISION 15, CHAPTER 4 OF THE ELECTIONS CODE**

6 WHEREAS, the election results for the Presidential General Election, held on November 8,
7 2016, have been presented to the Board of Vallecito Union School District by the County Clerk,
8 following the canvass of said election;

9 NOW, THEREFORE, BE IT RESOLVED, that the Board of the Vallecito Union School District
10 of the County of Calaveras hereby accepts the canvass of the returns of the General Election, held
11 on November 8, 2016, as delineated in Exhibit A attached hereto and made a part hereof, is hereby
12 accepted;

13 ON A MOTION by Board Member _____, seconded by Board Member
14 _____, the foregoing Resolution was duly passed and adopted by the Board of the
15 Vallecito Union School District of the County of Calaveras, State of California this 14th day of
16 December 2016, by the following vote:

17 AYES:

18 NOES:

19 ABSENT:

20 ABSTAINED:

21 _____
22 Board President
23 Vallecito Union School District

24 ATTEST:

25 _____
Secretary to the Board



COUNTY OF CALAVERAS

REBECCA TURNER
Clerk-Recorder-Registrar of Voters

891 Mountain Ranch Road, San Andreas, CA 95249

Recorder: (209) 754-6372
Elections: (209) 754-6376
Clerk: (209) 754-6371
Fax: (209) 754-6733

TO: Special Districts *RD*
FROM: Robin Glanville, Clerk-Recorder-Election Coordinator
DATE: December 5, 2016
RE: Certified Statement of Results for the November 8, 2016 General Election

The enclosed Certified Statement of Results is being sent to you pursuant to Elections Code section 15372.

If you have any questions or need further information please contact the Election's Office at (209)754-6376.

Enclosures:
Certificate of Results
Statement of Votes Cast
Sample Resolution
Sample Oath of Office

Certificate of Election

OFFICE OF COUNTY CLERK

County of Calaveras, State of California

This is to certify that

At the General Election held on the 8th day of November, 2016,

Susan E. Singleton

was elected to the office of

Vallecito Union School District

as appears by the official returns of said election and the statement of votes cast on file in my office.

In Witness Whereof I hereunto affix my hand and official seal this 2nd day of December, 2016.



County Clerk

Certificate of Election

OFFICE OF COUNTY CLERK

County of Calaveras, State of California

This is to certify that

At the General Election held on the 8th day of November, 2016,

Jason Burita

was elected to the office of

Vallecito Union School District

as appears by the official returns of said election and the statement of votes cast on file in my office.

In Witness Whereof I hereunto affix my hand and official seal this 2nd day of December, 2016.



County Clerk

CERTIFICATE OF COUNTY CLERK TO RESULTS OF THE CANVASS OF THE
GENERAL ELECTION

STATE OF CALIFORNIA)
) SS.
COUNTY OF CALAVERAS)

I, Rebecca Turner, County Clerk of said County, do hereby certify that, in pursuance to the provisions of Elections Code Section 15300, et seq., I did canvass the results of the votes cast in the General Election, held in said County on November 8, 2016 for the elective public offices that were submitted to the vote of the voters, and that the Statement of Votes Cast to which this certificate is attached, shows the number of votes cast in the Vallecito Union School District in said County and in the respective precincts therein, and that the totals of the respective columns and the totals as shown for each candidate are true and correct.

Witness my hand and official seal this 2nd day of December, 2016.

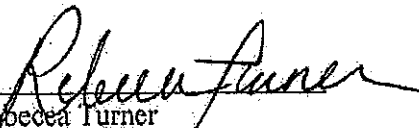
Rebecca Turner
County Clerk

	VALLECITO UNION SCHOOL DISTRICT 2 TO BE ELECTED									
	RV EO GT IE SR TS E R E D	BC AA LS LT O T S	TP UE RR NC OE UN TT A G E	SES U. I S A N L E T O N (NON)	RE AM LE PR H O N (NON)	CAG A. O R R O D L O N (NON)	LG IW NI DN S A Y (NON)	JB AU SR OI NT A (NON)	QV VO ET RE S	UV NO DT EE RS
8 PRECINCTS										
COUNTY TOTAL	8466	7041	83.17	2871	1468	583	1322	2319	10	2822
VOTING PRECINCTS	8466	7041	83.17	2871	1468	583	1322	2319	10	2822
CONGRESSIONAL 4	8466	7041	83.17	2871	1468	583	1322	2319	10	2822
STATE ASSEMBLY 5	8466	7041	83.17	2871	1468	583	1322	2319	10	2822
BOARD OF EQUALIZATION	8466	7041	83.17	2871	1468	583	1322	2319	10	2822
SUPERVISORIAL 2	932	770	82.62	29	15	6	15	18	0	27
SUPERVISORIAL 3	6218	5200	83.63	2632	1298	543	1222	2133	10	2558
SUPERVISORIAL 4	1316	1071	81.38	210	155	34	85	168	0	237
SUPERVISORIAL TOTAL	8466	7041	83.17	2871	1468	583	1322	2319	10	2822
UNINCORPORATED AREA	8466	7041	83.17	2871	1468	583	1322	2319	10	2822

8 PRECINCTS	VALLECITO UNION SCHOOL DISTRICT 2 TO BE ELECTED									
	R E O G T I E S R T S E R E D	B C A A L S L T O T A L S	T P U E R R N C O E U N T T A G E	S E S U I S A N L E T O N (NON)	R E A M L E P R H S O N (NON)	G A G A O R R O D L O N (NON)	L G I W N I D N S A Y (NON)	J B A U S R O I N T A (NON)	O V V O E T R E S	U V N O D T E E R S
0008 215 Mountain Ranch	932	770	82.62	29	15	6	15	18	0	27
0014 310 Arnold West	1127	927	82.25	410	224	119	166	412	0	522
0015 320 Central Arnold	817	681	83.35	339	138	80	149	302	0	354
0016 330 Arnold East	851	727	85.43	339	155	86	163	323	2	386
0017 350 Forest Meadows	1277	1103	86.37	553	273	113	272	433	0	559
0018 360 Murphys West	1143	932	81.54	528	253	76	267	334	0	406
0019 370 Murphys East	1003	830	82.75	463	255	69	205	329	8	331
0020 410 Rural Angels	1316	1071	81.38	210	155	34	85	168	0	237
GRAND TOTALS	8466	7041	83.17	2871	1468	583	1322	2319	10	2822

**STATEMENT OF VOTES CAST AT THE GENERAL ELECTION
HELD ON NOVEMBER 8, 2016**

As a result of the canvass of the General Election held on November 8, 2016, the following candidates, having received a plurality of the votes cast for their respective county offices, are declared elected for a term of four (4) years:

Mark Twain Union Elementary School District

Diane L. Bateman
Jennifer A. Eltringham
Margaret "Maggie" Rollings

Vallecito Union School District

Jason Burita
Susan E. Singleton

Supervisor - District 1

Gary N. Tofanelli

Calaveras Consolidated Fire Protection District

Keith Hafley
Sam L. Harris
Ken Glissman
Tim Runion

Mark Twain Health Care District

Susan Atkinson
Randy Smart

Calaveras County Water District Division 1

Scott Ratterman

As a result of receiving a plurality of the votes cast for their respective county offices, are declared elected for a term of two (2) years:

Supervisor-District 5

Clyde Clapp

Mark Twain Health Care District

Debbie Sellick

As a result of having no opposition and therefore it not being required to be on the ballot, the following persons are declared elected for a term of four (4) years:

Calaveras Unified School District - Trustee Area 1

Sherri Reusche

Calaveras Unified School District - Trustee Area 3

Dennis Dunnigan

Bret Harte Union High School District

Roger Orman
Tony Tyrell
Jeff Rasmussen

Angels City Council

Linda Hermann
Susan G. Rudolph

Appaloosa Road Community Services District

Steve Metz

San Andreas Sanitary

Todd G. Fischer

Erle Donald Young "Don"

Michelle Turner

Angels Camp Veterans Memorial District

Daniel B. Brooks

Caroline Althea Schirato

Ebbetts Pass Veterans Memorial District

Lewis P. Monell

Richard Elliott

Albert R. Napier

Jenny Lind Veterans Memorial District

Frank Garza

James L. Sullivan

San Andreas Veterans Memorial District

George C. Fry, Jr

West Point Veterans Memorial District

Samuel Hernandez

Guy Johnstone

Calaveras County Water District Division 5

Jeff Davidson

As a result of having no opposition and therefore it not being required to be on the ballot, the following persons are declared elected for a short term of two (2) years

Wallace Community Services District

Eric Jason Baysinger

Altaville Fire Protection District

Don August Warner

Calaveras Consolidated Fire Protection District

Patrick Brown

Ebbetts Pass Veterans Memorial District

Gary M. Lewis

Jenny Lind Veterans Memorial District

Steven Albert Vaughn

West Point Veterans Memorial District

Draza Nikolic

Vincent S. Moody

**VALLECITO UNION SCHOOL DISTRICT
BOARD OF TRUSTEES
MEETING SCHEDULE**

Jan 2017 - June 2018

Unless otherwise notified, all meetings are held on the third Wednesday of every month at the Vallecito Union School District Office.

Until further notice, the Open Public Session will commence at 4:00 p.m. and immediately convene to Closed Session. Open Session will re-convene at 5:30 p.m.

<u>DATE</u>	<u>LOCATION</u>	<u>DATE</u>	<u>LOCATION</u>
JANUARY 25, 2017	MICHELSON	*JANUARY 24, 2018	MICHELSON
FEBRUARY 15, 2017	MICHELSON	*FEBRUARY 14, 2018	MICHELSON
MARCH 8, 2017	AVERY MIDDLE	*MARCH 7, 2018	AVERY MIDDLE
APRIL 19, 2017	DISTRICT OFFICE	*APRIL 18, 2018	DISTRICT OFFICE
MAY 10, 2017	HAZEL FISCHER	*MAY 9, 2018	HAZEL FISCHER
JUNE 7, 2017	DISTRICT OFFICE	*JUNE 6, 2018	DISTRICT OFFICE
JUNE 21, 2017	DISTRICT OFFICE	*JUNE 20, 2018	DISTRICT OFFICE
AUGUST 9, 2017	DISTRICT OFFICE	<i>*Tentative dates - to be confirmed at the December 2018 organizational meeting</i>	
SEPTEMBER 20, 2017	HAZEL FISCHER		
OCTOBER 18, 2017	DISTRICT OFFICE		
NOVEMBER 15, 2017	AVERY MIDDLE		
DECEMBER 6, 2017	DISTRICT OFFICE		

Board approved 12/14/16

MON	BUDGET	OTHER	PERSONNEL
JAN	Audit Approval Governor's Budget Report Budget Assumptions Assessor's Report	Williams Complaint Sum (Oct-Dec) Approve SARC's	Complete formal tchr. Observations Begin Superintendent Evaluation Certificated Tie Breaker Resolution
FEB	FCMAT Study Finance Workshop	Resolution "Week of Administrators"	Cert./Class. Staff of Year Reopen Cert. Agreement Reopen Class. Agreement Cert/Class Seniority Lists 2017-18 Preliminary Staffing
MAR	2 nd Interim Report	Create Facilities Advisory Committee-VTA, CSEA, Princ., Gretchen, Parent, Community Mbr. Begin the following district plans: DLAC Plan Facilities Master Plan Technology Master Plan School Site Plans Wellness Plan Safety Plan	Respond to Cert. Re-openers Respond to Class. Re-openers Notice Prin. of non-rehire by 3/1 Notice Tchrs. of non-rehire and/or layoff by 3/15 Complete Supt evaluation and notify Supt. re: contract by 3/15
APR		Williams Complaint Sum (Jan- Mar) Declaration of Need for Fully Qualified Educators Resolution-Certificated Empl. Week	Complete written tchr. Summary annual evaluations by 4/25 Notify Class. of non-rehire by 4/29
MAY	Preliminary Budget Revise LCAP Plan – Board review for County Approval	Resolution-Classified Empl. Week Facilities Advisory Committee recommendations to Board	Complete 9 & 10 mo. Employee Evaluations by 5/15 Notify Cert. of non-rehire by 5/15 Staff Recognition - Retirees
JUN – Two Mtgs.	1st Meeting - Public Hearing: Local Control Accountability Plan (LCAP) Budget Resolution – Education Protection Account 2nd Meeting: Adopt Budget Adopt LCAP Technology Master Plan Update Facilities Master Plan Update Consolidated App School Site Plans Wellness Plan Safety Plan	Feeney Park Calendar	Class. evaluations (12 mo.) by 6/30 Appoint Coaching Staff Appoint Athletic Director(s)
JUL	File Budget at CCOE		
AUG		Williams Complaint Sum (Apr – Jun)	Notify Cert. of termination due to insufficient rev. limit increase by 8/15
SEPT	Public Hearing: Certification of Student Access to Textbooks Unaudited Actuals Resolution - Gann Limit Approve Booster Club Apps Resol. -Acctg. of Dev Fees-Draft	Report on CAASPP Results	Staff Recognition for years of service Introduction of New Staff Teacher Assignment Rpt –Credentials Appoint Coaching Staff
OCT	Resol.- Acctg. of Dev Fees-Adopt	Resolution "Red Ribbon Week" Review Policies– BP/AR 5116.1, BP/AR 6145 Williams Complaint Sum (Jul – Sept)	
NOV		CELDT/ELL Report	Appoint Coaching Staff
DEC	1 st Interim Report	Annual organizational mtg.	

Board Policy will be addressed as needed.

DESIGNATED BOARD COMMITTEE REPRESENTATIVES

Board Approval 12/14/16

Governance, Leadership and Culture of Excellence

LCAP Plan (2)

Tom Pratt

**Special Ed Administrative
Unit (SELPA)**

Tom Pratt

Governance Committee (2)

Coordinates:

Annual Board Self Review

Board Trainings

Annual Supt. evaluation

Curriculum and Instruction

**Curriculum and
Instruction Council
(C & I)**

Technology

Calendar

Student Wellness

Wellness / Prevention / Safety
Colby Barker

Community Relations

Community Relations (2)

Tom Pratt

Rural School Boards Assoc. (2)

Meetings scheduled as needed

Benefits Advisory

VALLECITO UNION SCHOOL DISTRICT
EXPENDITURE REPORT
DATE: December 2, 2016

VENDOR NAME

AMOUNT

These payments were previously sent to the Board members to review for payment Nov 3 - Dec 2, 2016

Fund 01

1	Al Cal Glass Supply - Maintenance	145.42
2	Accurate Label - AMS Office Supplies	111.95
3	Alford, Christy - Mileage Reimbursement	86.40
4	Allured, David - Mileage Reimbursement	164.70
5	AMS Net - Technology Support	3400.00
6	Arnold Auto - Maintenance	29.00
7	Arnold Tire and Auto Care - Maintenance	20.00
8	Art In Action - Art Supplies	583.00
9	Bank of America - Meeting, Technology Supplies, Maintenance, & Conference	2958.35
10	Berri, Sam (Sam Berri Towing) - Transportation	750.00
11	Bertini, Paul, - Service AMS Gym Boiler	1138.00
12	Big Trees Market - Meeting Supplies	3.21
13	Blunt, Anna - Workshop Reimbursement	50.00
14	CA Chamber of Commerce - Labor Poster	18.57
15	CA Kindergarten Association - Conference	930.00
16	CA, State of Dpt of Toxic Substance - Maintenance	175.00
17	Cal - Waste - Maintenance	481.04
18	Calaveras Enterprise - Board Member Ad	383.00
19	Calaveras Lumber Co Inc - Maintenance	28.65
20	California Valued Trust - Benefits	160042.83
21	CMC Asilomar - Conference	450.00
22	Document Tracking Services - License Agreement	1245.00
23	Doyle, Tobie - Conference Meal Reimbursement	80.00
24	Ebbetts Pass Lumber Co Inc - Maintenance	791.37
25	Educational Data Systems - Testing Materials	9.09
26	Encore Data Products, Inc - Technology	427.86
27	Epic Sports - HFE Sports Equipment	79.99
28	Evan Moor Educational Publishers - Speech Therapy Supplies	104.23
29	Foss, Trudi M - Speech Therapy Services	2400.00
30	Francis, Melissa - Mileage Reimbursement	62.10
31	Gatekeeper Systems - Transportation	5749.12
32	Gateway Press, Inc - School Office Supplies	199.95
33	General Plumbing Supply Co. - Maintenance	84.21
34	Heermance, Alison - Classroom Supply Reimbursement	351.72
35	Hessels, Amy - Classroom Materials Reimbursement	269.00
36	Hungerford, Jared - Meeting Supplies & Meal Reimbursement	359.52
37	Interstate Truck Center - Transportation	127.59
38	IXL Learning - Site License Upgrade	425.00
39	Jones, Shannon - Classroom Supply Reimbursement	58.06
40	Kelly's Back Flow Services Inc - Maintenance	270.00
41	Lane, Michelle - Classroom Supply Reimbursement	45.78
42	Lewis, Shonna - Meals for Conference	92.00
43	Mark Twain Union Elementary - NGSS Training Reimbursement	1720.00
44	McReynolds, Gretchen - Mileage Reimbursement	209.52
45	Miller, Gene - Maintenance	7.00
46	Miller, Linda - Classroom Supply Reimbursement	73.22
47	MNJ Technologies Direct - Technology	617.08
48	Modesto Janitorial - Maintenance	363.41
49	Murphys Station - Maintenance	68.65
50	New Frontier Auto Supply - Transportation	111.61

VENDOR NAME

AMOUNT

These payments were previously sent to the Board members to review for payment Nov 3 - Dec 2, 2016

51	Office Depot - Classroom Supplies	866.73
52	Ogen, Don - Meeting Supply Reimbursement	87.70
53	Oliver, Laura - Meals for Conference	92.00
54	Overholtzer, Sandy - Speech Therapy Services	2240.80
55	Pyramid Educational Consultants, Inc - Conference & Text Books	1676.64
56	School Specialty - Room Divider For HFE	763.38
57	Schweiso, Trina - Conference Meal Reimbursement	80.00
58	Sederquist, Sven - Mileage & Hotel Reimbursement	181.61
59	Shoes For Crews - Maintenance	54.18
60	Smith, Byron C. - Legal Services	1466.28
61	Smith, Timothy Lee - Art Instruction for AMS & AME	436.84
62	Tera Grand Corporation - Technology	526.57
63	Thinking Social Publishing, Inc - Conference	990.40
64	Tifco Industries - Transportation	7778.57
65	Uline - Maintenance	632.36
66	Union Democrat, - Board Member Ad	85.20
67	Verizon - Emergency Cell	0.88
68	Worthington Direct - Technology for AME, AMS, HFE	4806.70

Fund 13

69	Uline - Kitchen Supplies	124.00
70	CA Dept. of Education - Food Distribution Program	158.60

Fund 25

71	Angels Sheet Metal - Replace HVAC at AME	9785.00
72	Hankin Specialty Elevators, Inc - AME Stage Lift	1000.00
73	Insight Systems Exchange - Technology for AME, HFE, AMS	9526.36

VALLECITO UNION SCHOOL DISTRICT

12/9/2016
AMOUNT

VENDOR NAME

Fund 01

1	Alford, Christy - Mileage Reimbursement	43.20
2	Battaglia, Gail - Conference Hotel, Meal & Mileage Reimbursement	359.31
3	Biz Chair - Technology	1185.01
4	Cal-Waste - Maintenance	481.04
5	Casselberry, Joan - Education Expense Reimbursement	5,000.00
6	CDK Supply - Maintenance	344.00
7	Center For The Collaborative Classroom - Sipps Materials	672.21
8	Ebbetts Pass Lumber Co, Inc - Maintenance	1,314.48
9	Gorman, Nancy - Conference Hotel, Meal, & Mileage Reimbursement	245.59
10	Guitierrez, Jane - Mileage, Meal, & Classroom Material Reimbursement	214.08
11	Modesto Janitorial - Maintenance	208.46
12	Office Depot - Classroom & Office Supply Orders	525.13
13	Overholtzer, Sandy - Speech Therapy Services	2,730.90
14	Rosenquist, Sue - PE Equipment Reimbursement	130.63
15	Weidmann, Tim - Meal Reimbursement	80.00
16	Tera Grand Corp. - Technology	104.47
17	Uline - Maintenance	584.34

VALLECITO UNION SCHOOL DISTRICT

Minutes of the Regular Meeting

11-16-16

PUBLIC MEETING CALLED TO ORDER – President Pratt called the meeting to order at 2:05 p.m.

ESTABLISHMENT OF QUORUM

Tom Pratt – President
Colby Barker – Clerk
Wayne Harrison
Carol Gordon – *Absent*

ADMINISTRATION PRESENT: Don Ogden, Superintendent / Principal

APPROVAL OF AGENDA -- Motion was made by Mr. Barker, seconded by Mr. Harrison to pull item C.3A and approve the agenda. Motion passed 3-0-1 (Gordon absent)

PUBLIC COMMENT ON ANY ITEM ON THE CLOSED SESSION AGENDA - None

CLOSED SESSION

**A. PERSONNEL
ADMINISTRATION**

Public Employee Evaluation – Superintendent

OPEN SESSION – 3:05 p.m. – President Pratt reconvened open session.

ADMINISTRATION PRESENT: Brett Loring, Principal – Michelson School

STAFF PRESENT: Gretchen McReynolds, Cheryl Boyd, Sue Rosenquist

OTHERS PRESENT: Susan Singleton, Linda Wadle, Sarah Wilson

BOARD MEMBER INTERVIEWS – *Byron Smith, Attorney at Law, conducted the Provisional Appointment proceedings. Mr. Smith explained the interview and voting process and asked the public or board members if they had any questions prior to the interviews. With no questions Mr. Smith had each candidate draw a “straw” and the first person chosen, Sarah Wilson, was asked to take a seat and Linda Wadle was excused upstairs to await her turn for interview. Mrs. Krpan was called after the second interview.*

Board member candidates: Sarah Wilson, Linda Wadle, Julie Krpan (via telephone)

The Board asked the following questions of every candidate:

1. Please tell us about your current and previous involvement with the Vallecito Union School District and any other public agency. How do you believe that experience would assist you in your role as a Board Member for the Vallecito Union School District?
2. Do you have any specific initiatives or actions that you believe would help the students or VUSD?
3. What would you do if you received a verbal complaint from an employee or a member of the public about a classified, certificated, or administrative employee?
4. What is your motivation to be a board member?
5. What do you see as the most important role that a board member plays in the success of VUSD students?
6. The Vallecito Union School District Governing Board meets at least once a month. Please describe what you believe a board member must do to remain informed on key issues affecting the District? Please give some specific examples of what you would do to accomplish this goal?

Once all candidates were interviewed Mr. Smith asked that the public have an opportunity to comment. Mr. Pratt thanked all of the candidates and let them know that he was in the same position six years ago, so no matter what the outcome is today, please run again.

Candidate Linda Wadle stated that she recently retired from the same school district Mr. Ogden worked at previous to Vallecito. Mr. Ogden and Mrs. Wadle clarified that they did not know each other. Mrs. McReynolds asked in the matter of full disclosure if any of the board members knew any of the candidates. Mr. Pratt stated that he knew Mrs. Wilson.

MINUTES OF THE REGULAR MEETING
VUSD GOVERNING BOARD
NOVEMBER 16, 2016

Hazel Fischer teacher, Sue Rosenquist, stated that she appreciates the candidates for their interest in the board position. She also mentioned that she has known Linda Wadle for many years as her children went through the Vallecito school system.

Mrs. Singleton commented that time is very important and we have two teachers on the board and realizes that there are many demands when working a full time job. Looking for someone with time as the commitment is more than a once a month meeting.

At this point Mr. Smith closed the public comment session and allowed the board to deliberate called for a motion. After discussion Mr. Pratt stated that he feels it is important to have diversity of opinion and the board has two teachers and one retired teacher and feels someone in a private industry and/or with young children going through the schools would be able to bring a variety of experience and diversity. With this said Mr. Pratt made a motion to nominate Sarah Wilson. Mr. Barker seconded the motion. Motion passed 3-0-1 (Gordon absent) The delivery of the Oath of Office was given by Superintendent Donald Ogden.

CLOSED SESSION -- President Pratt adjourned to Closed Session at 4:30 p.m.

A. CLASSIFIED

Public Employee Discipline/Dismissal/Release
Public Employment

Modify 4 hrs./day Instructional Aide position # 2112 to 4 hrs./day Health/Special
Circumstance/Full Inclusion Aide at HFE

Modify 8 hrs./day Computer Instructor/Technician position # 2151 to 5.75 hrs./day
Creation of District Wide 5.75 hrs./day, 260 days/year (12 month), Computer
Instructor/Technician position # 2153

Cell phone stipend for District Wide Skilled Maintenance Worker

Public Employee Appointments

- 5.75 hr./day Health / Special Circumstance / Full Inclusion Aide @ AMS

B. CONFERENCE WITH LABOR NEGOTIATOR – Donald Ogden – Superintendent

- Vallecito Teachers' Association

OPEN SESSION – President Pratt re-convened the open session at 5:40 p.m. and announced the following action was taken in closed session:

A motion was made by Harrison, seconded by Barker to accept the resignation of a Computer Instructor/Technician position # 2151, effective December 16, 2016. Motion passed 4-0 – Ayes – Pratt, Barker, Harrison, Wilson; Absent – Gordon

ADDITIONAL STAFF PRESENT: Tobie Doyle, Linda Rasmussen, Anna Garrison, Ali Heermance, Michelle Lane, Michelle Wright

COMMENTS / QUESTIONS / COMMUNICATION FROM THE AUDIENCE

AMS Student Representative - None

Vallecito Teachers' Association – Michelle Wright welcomed and congratulated the new board members; staff feels most thankful this Thanksgiving week to work in this district and we are in a unique position working with our children of our district; adjusting well with new staff and substitutes; VTA is working with Mr. Ogden on incentives to attract high quality teaching staff; working on piloting new ELA curriculum

California School Employees Association – Vallecito Chapter 748 – None

General Public / Community Groups / Parent Groups - None

Staff Members –Michelle Lane reported on the District's ELL program

ANNOUNCEMENTS AND COMMUNICATIONS

Board Members – Mr. Harrison has been busy with a kitchen tear-out project; Mr. Barker attended the AME Halloween Carnival, County Wide Future Concern of Education meeting; Mrs. Wilson thanked the board, gave a short introduction bio and is excited for the opportunity to work with the Board; Mr. Pratt attended SELPA, parent club meetings at AME/HFE, voting at AMS-Hessels classroom, screened provisional board candidates, Veteran's celebration at AME, congratulations to our two board member elects – Susan Singleton and Jason Burita.

MINUTES OF THE REGULAR MEETING
VUSD GOVERNING BOARD
NOVEMBER 16, 2016

Don Ogden, Superintendent:

- Invite Board Member elects to the December 14th Closed Session
- Board update is emailed on Wednesday's
- Teachers are collaborating on the ELA piloting and standards for each grade
- Speech Therapist hired this year; considerable student case load so the district has retained Vocovision

REGULAR AGENDA ITEMS

A. CONSENT AGENDA

- A.1 Warrants
A.2 October 19, 2016 Regular and Special meeting minutes
A.3 Modify 4 hrs./day Instructional Aide position # 2112 to 4 hrs./day Health/Special Circumstance/Full Inclusion Aide at HFE
A.4 Modify 8 hrs./day Computer Instructor/Technician position # 2151 to 5.75 hrs./day
A.5 Creation of District Wide 5.75 hrs./day, 260 days/year (12 month), Computer Instructor/Technician position # 2153
A.6 Cell phone stipend for District Wide Skilled Maintenance Worker - \$600 annual
A.7 Agreement for Speech services between VUSD and Vocovision
Motion: Harrison **Second:** Barker **Vote:** 4-0-1 (Gordon absent)

B. GENERAL BUSINESS

- B.1 County of Calaveras Planning Dept. – Discussion regarding zoning amendment of Commercial Way property for the purpose of permitting an indoor cannabis cultivation operation.

C. PERSONNEL

- C.1 ADMINISTRATION
C.1A Public Employee Evaluation – Superintendent – no action
- C.2 CLASSIFIED
C.2A Appointed Steve Casey as the 5.75 hr./day Health / Special Circumstance / Full Inclusion Aide @ AMS contingent on passing the NCLB exam
Motion: Harrison **Second:** Barker **Vote:** 4-0-1 (Gordon absent)
- C.3 CERTIFICATED
C.3A Pulled Board's consideration to approve a VTA Tentative Agreement Addendum

ITEMS FOR NEXT BOARD MEETING –

- December Board Calendar – Review for Site Visits
12/1 – Sport – O – Rama at AMS – Colby
12/8 – 3 pm C & I @ DO
12/9 – 7 pm “Elf” movie night @ AMS
12/13 – 6:30 pm AME Winter Program
12/14 – VUSD Board Mtg. @ DO
12/15 – 6 pm HFE Winter Program

December 14, 2016, 5:30 p.m. at the District Office
Personnel
Annual Organizational Meeting

ADJOURNMENT – Member Harrison made a motion to adjourn, seconded by Member Barker and with no further discussion President Pratt adjourned the meeting at 6:15 p.m.

Secretary to the Board

Clerk of the Board



HANKIN SPECIALTY ELEVATORS, INC
3237 Fitzgerald Road
Rancho Cordova, CA 95742
Phone (916) 381-2400 Fax (916) 381-2481

Contractors License
CA / 917257
NV / 78801
NV / 78802

**Murphys Elementary
Wheelchair lift**

October 14, 2016

PROVIDE ONE (1) GARAVENTA OPAL
37x51 platform, 42" raised height,
Open lift with safety pan under moving carriage
keyed rocker switch controls
standard color, satin grey
floor mounted with ramp provided
straight through entry exit pattern
power door openers due to no 18" clearance to the strike side
hydraulic operation with battery back up with min 5 trips up and down
pit switch per code
2 standard gates with closers. Upper is a fixed gate, lower moves with carriage

Pricing for above lift installed **\$21000.00**

PRICING INCLUDES: LIFT, FREIGHT, TAX, LABOR, NEVADA WEIGHT TEST AND ELEVATOR PERMIT, offloading, setting in place, control wiring, unlimited site visits for coordination

PRICING EXCLUDES: GENERAL CONSTRUCTION PERMITS AND FEES, PENALTIES AND LIQUIDATED DAMAGES, site modifications to accept lift required dimensions MAIN POWER SUPPLY AND DISCONNECT, conduit runs for controls, site modifications to accept lift, emergency lighting in case of power outage

You will need 18" space to the side of the gate strikes at each landing

The upper landing needs to have a solid wall on it to hold the upper landing gate.
See dimensions on the drawings I included with the quote.

Your electrician brings 120 vac, 20 amp circuit to the lift and provides a fused knife disconnect
2 pole, lockable at the LOWER landing. He will also have two conduit runs one to each call/send station at top and bottom as well as a conduit run to the upper gate

Pricing good for 90 days

Sincerely

**Steve V. Caldwell
Hankin Specialty
800-831-8395 OFFICE
916-417-9110 cell**

GENESIS OPAL LIFT:

Code Reference: ASME A18.1 "Safety Standard for Platforms Lifts & Stairway Chairlifts", or California Title 8.

General: Color - Standard (Anodized aluminium extrusions champagne finished with 16 ga. galvanized steel panels/steel posts powder coated Satin Grey)
 Indoor Unit - Floor Mount (Ramp Required)
 Number of Stops - Two Stop Unit



Drive Mast Model - GVL-OP-42
 Chain Hydraulic drive system c/w Continuous Mains Power with Auxiliary Battery Power System, Platform Emergency Lowering (shipped loose), Shoring Pin, & Pressure Gauge
 Motor - 2.2 kW, (3.00 HP), 24 VDC
 Travel Speed - 340 kg @ 5.2 m/min [750 lb @ 17 ft/min]
 Power Supply - 120 VAC, single phase, 60 Hz, on a dedicated 15 amp. circuit
 Equipped with - Pit Switch Kit

Controls: Platform Controls - Rocker Type c/w Rocker (Toggle) Switch and Illuminated Round (push/pull) Emergency Stop Switch/Audible Alarm
 Lower Landing Call Station - Rocker Type Surface Wall Mount
 Upper Landing Call Station - Rocker Type Surface Wall Mount
 Equipped with - Keyed Operation Kit

Platform: Size - Standard c/w under platform obstruction sensing plate, tubular grab rail and 43 1/4" high walls. Side walls have 16 Ga galvanized steel sheet infill panels
 Configuration - Straight Through (180°) Exit/Entry
 Capacity - Maximum 340 kg [750 lb] operating load
 Equipped with - Platform Courtesy Lights

Door/Gates: Lower - 36" wide Steel Platform Gate c/w Mechanical Interlock & Garaventa Power Door Operator
 Upper - 36" wide Steel Platform Gate c/w Mechanical Interlock & Garaventa Power Door Operator

Opal: Total Unit Weight -- Approximately 500 lb [227 kg]
 MAXIMUM Lifting Ht. (H1) - 45" lower floor to upper floor
 Note: Installer can reduce the lifting height as required during installation.
 Equipped with - 1:8 Fixed Ramp

A	INITIAL RELEASE	UNITS: INCHES	OCT/14/16	AU			
REV.	SCALE: 1:20	TOLERANCES: DIMENSIONAL ±1/32	ANGULAR ±0.5°	PROJECTION: 	DATE	DRN.BY	CHK.BY
 7505 - 134A STREET SURREY, BC, CANADA V3W 7B3 PH: ++1 604 594 0422 FAX: ++1 604 594 9915 http://www.garaventalift.com		GENESIS OPAL - IGOLDD DRAWING MURPHYS ELEMENTARY 1234 MAIN STREET MURPHYS HANKIN SPECIALTY ELEVATOR			PAGE 1 OF 4 29403-IG-A		



DEDICATED CIRCUIT SUPPLIED BY OTHERS:
 120 VAC / 1 PHASE - 60 Hz.
 Conduit and devices to suit local codes and
 a recommended 15 amp. dedicated circuit.

**** NOTE:** Recommended Tieback Bracket Height Shown
 (Minimum Tieback Height = 80% of Ht).

Attach Gate Frame Posts
 to Existing Structure Typ.

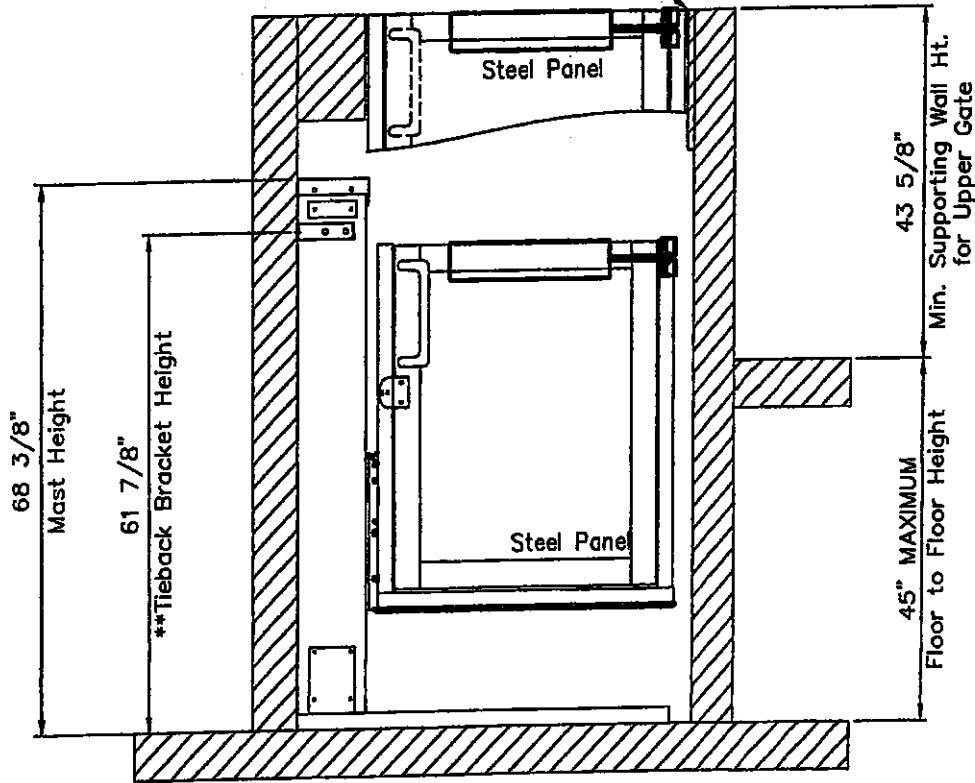

A	INITIAL RELEASE	UNITS: INCHES	OCT/14/16	AU		
REV.	SCALE: 1:20	TOLERANCES: DIMENSIONAL ±1/32 ANGULAR ±0.5°	PROJECTION:	DATE	DRN.BY	CHK.BY



7505 - 134A STREET
 SURREY, BC, CANADA V3W 7B3
 PH: ++1 604 594 0422
 FAX: ++1 604 594 8915
<http://www.garaventalift.com>

GENESIS OPAL - IGOLDD DRAWING

MURPHYS ELEMENTARY
 1234 MAIN STREET
 MURPHYS

PAGE 2 OF 4

HANKIN SPECIALTY ELEVATOR

29403-IG-A

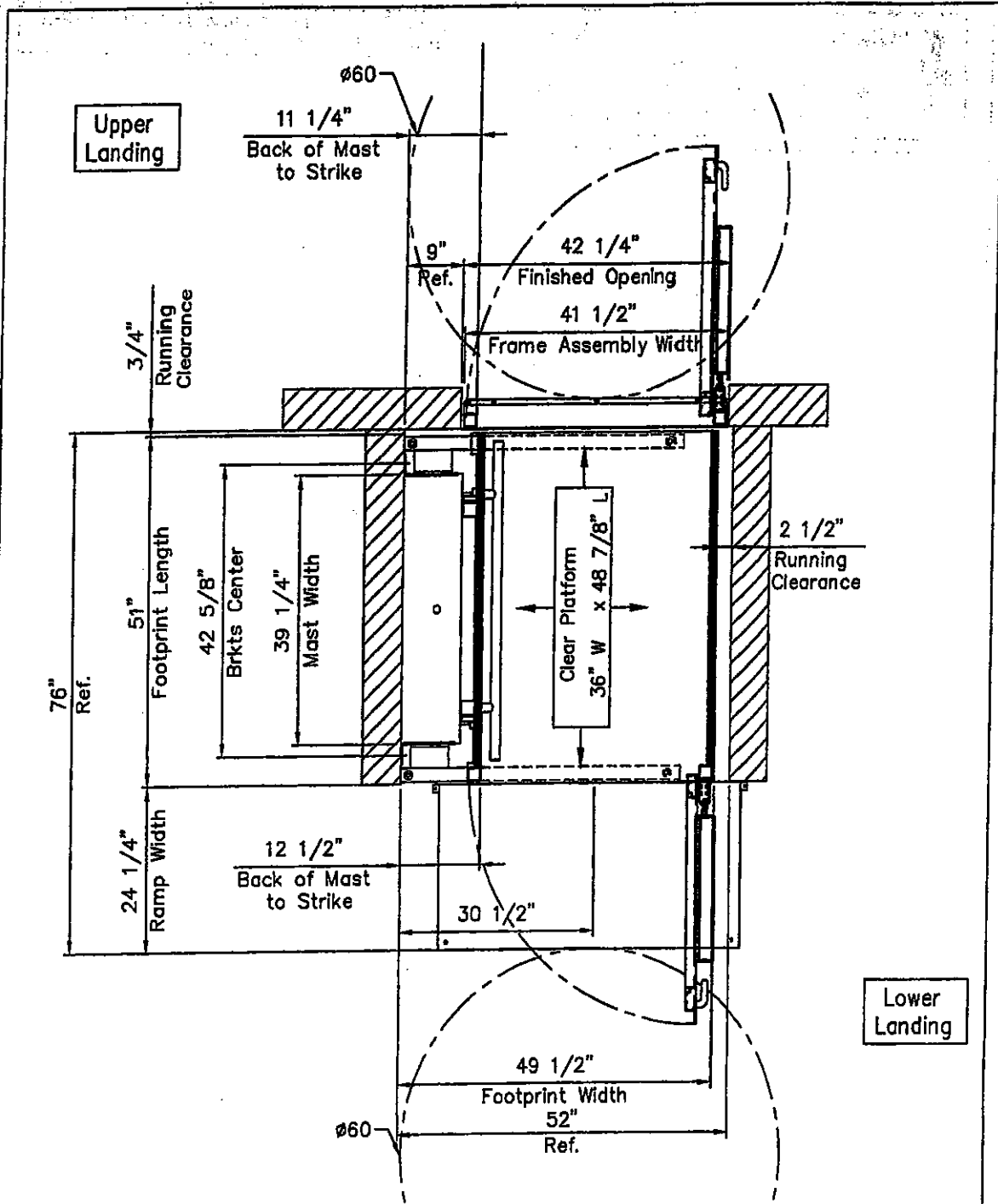

A	INITIAL RELEASE	UNITS: INCHES	OCT/14/16	AU	
REV.	SCALE: 1:20	TOLERANCES: DIMENSIONAL $\pm 1/32$	ANGULAR $\pm 0.5^\circ$	PROJECTION:	DATE DRN.BY CHK.BY



7505 - 134A STREET
 SURREY, BC, CANADA V3W 7B3
 PH: ++1 604 594 0422
 FAX: ++1 604 594 9915
<http://www.garaventalift.com>

GENESIS OPAL - iGOLDD DRAWING
 MURPHYS ELEMENTARY
 1234 MAIN STREET
 MURPHYS
 HANKIN SPECIALTY ELEVATOR

PAGE 3 OF 4

29403-IG-A

SYM.	DESCRIPTION	VALUE (MAX)
F1 =	PAYLOAD (MAX.)	3335 N [750 lb]
	CAR (PLATFORM) WEIGHT	1110 N [250 lb]
F2	MAST WEIGHT	777 N [175 lb]
F3	FLOOR REACTION	4791 N [1079 lb]
F4	FLOOR REACTION	426 N [96 lb]
F5	TIEBACK BRACKET REACTION	2087 N [470 lb]

PLATFORM SIZE	L1	L2
Standard	688 [27 1/8"]	1145 [45 1/8"]

MODEL	MAST HEIGHT	TIEBACK HEIGHT
42"	1737 [68 3/8"]	1572 [61 7/8"]

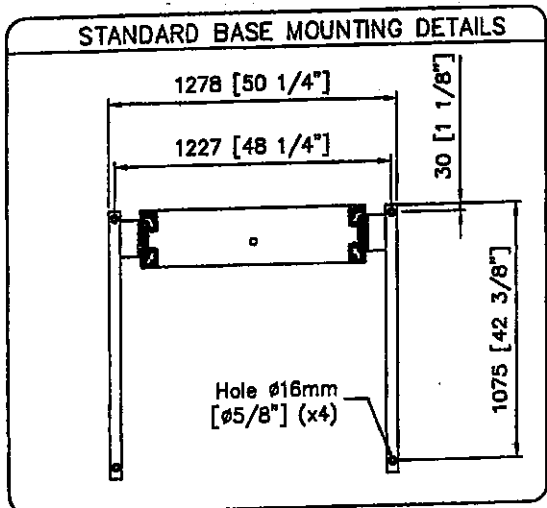
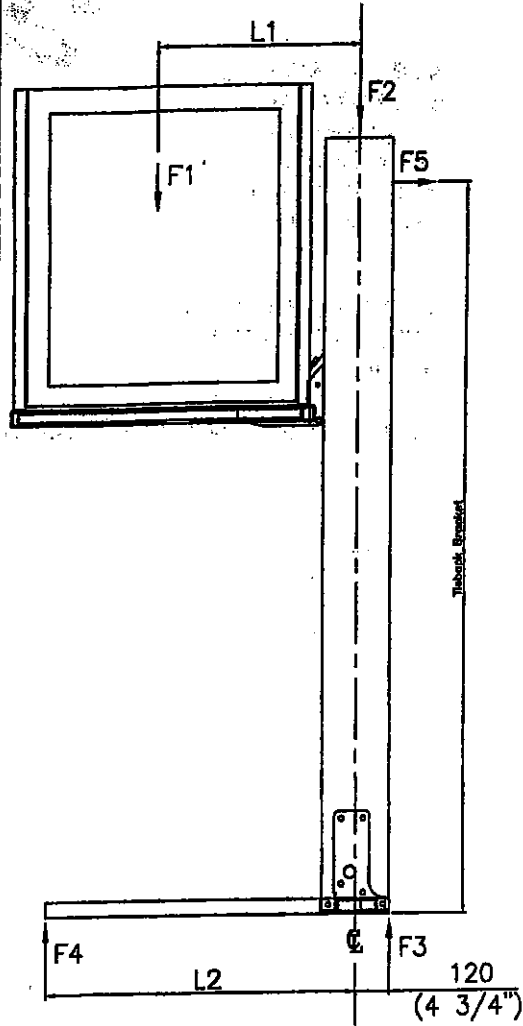

The information contained in this drawing constitutes the Intellectual Property, including, but not limited to, knowledge, trade secrets, and proprietary information which is the exclusive property of Garaventa Accessibility. All information contained in this drawing is to be held in the strictest confidence by the recipient, and is not to be copied, disclosed to, or transmitted to any third parties without the express written authorization of Garaventa Accessibility.

© 2005 GARAVENTA ACCESSIBILITY.

SPECIAL NOTE:

These are reaction forces generated by the lift. Adhere to local building codes, regulations, and safety factors for supporting structures. Consult a structural engineer or architect in your jurisdiction.

DETAIL 1 - OPAL MODEL LOADING DIAGRAM

A	INITIAL RELEASE	UNITS: INCHES	OCT/14/16	AU
REV.	SCALE: 1:20	TOLERANCES: DIMENSIONAL ±1/32	ANGULAR ±0.5°	PROJECTION:
		GENESIS OPAL - iGOLDD DRAWING MURPHYS ELEMENTARY 1234 MAIN STREET MURPHYS		DATE DRN.BY CHK.BY
7505 - 134A STREET SURREY, BC, CANADA V3W 7B3 PH: ++1 604 594 0422 FAX: ++1 604 594 9915 http://www.garaventalift.com		PAGE 4 OF 4		29403-IG-A
HANKIN SPECIALTY ELEVATOR				



**HANKIN SPECIALTY
ELEVATORS INC**
3237 Fitzgerald Road
Rancho Cordova CA 95742
Phone 916/381-2400
Fax 916/381-2481

Contractor's License:
CA # 917257
NV # 78801
NV # 78802

**MURPHYS ELEMENTARY
INCLINE WHEELCHAIR LIFT**
Devin Johnson
djohnson@vsd.k12.ca.us
One (1) Garaventa Xpress II Incline Wheelchair Lift

OCTOBER 14, 2016

Auto -fold platform
550 lb. capacity
Under platform sensing
Bi-directional ramp sensing
Integrated grab rail
Emergency stop on platform
Overspeed safety
Color: Champagne aluminum rails
Meets A.18 current codes
Battery Back-up

Power operated ramps
31 1/2" x 49 1/2" platform
Bronze anodized aluminum rails
Anti skid flooring
208 volt 1-phase main power required
One touch controls
Emergency lowering device
Automatic curved safety arms
CA State Elevator Inspection

Price, installed including tax

\$ 23500.00

Excludes: Penalties and liquidated damages.
All permits and fees.
Dedicated 208 single phase fused lockable disconnect.
Conduit runs for upper and lower call stations.
Support in wall to attach lift to by others.

Shipping: 6 to 8 weeks after receipt of approved shop drawings.
Terms: 10% down, 50% once lift goes to production, 30% when lift ships, balance due upon installation. 25% cancellation fee, 100% once lift goes into production.

Proposed By: steve caldwell

Accepted By: _____

XPRESS II INCLINED PLATFORM LIFT:

Code Reference: ASME A17.1 "Safety Code for Elevators and Escalators", Part XX (Commercial Public Buildings) and ASME A18.1 "Safety Standard for Platforms Lifts and Stairway Chairlifts"

Emergency Devices: Emergency stop switch on a control panel, under platform sensing, ramp sensing and grab rail.

Safeties: Overspeed governor on upper carriage drive, containing mechanical overspeed sensor and lock, with electrical drive cut-out protection.

Drive: Power Transmission: Worm gear reduction to a pinion moving on a fixedgear rack.

Motor: 0.75 HP

Power Supply: 208-240 VAC / 1 PHASE -- 50/60 Hz, on a dedicated 20 amp circuit.

Travel Speed: 4 m/min [13 ft/min] traveling up; 5 m/min [16 ft/min] traveling down.

Location: Indoor Lift

Attachment: Direct Mount Unit with 2"x8" & 2"x4" Boards

Platform: 800mm x 1250mm [31 1/2" x 49 1/4"] (Keyless)
The 16 ga. galvanized platform deck is finished with an electrostatically applied Non-Slip Black Sandex powder coat. The platform is equipped with a grab rail, hour counter and retractable passenger restraining arms.

Capacity: Maximum 250 kg [550 lb] operating load.



Color: Upper and lower rails and loading ramps are made of aluminum with a champagne anodized finish. The steel components of the lift are finished with an electrostatically applied and baked powder Satin Grey finish.

Ramps: Lower Ramp - Standard 185mm [7.25"]
Upper Ramp - Standard 185mm [7.25"]
Sideload - Not Required.

Call Stations: Lower Landing - Surface Mount c/w flush adapter (Keyed / Keyless - configurable)
Upper Landing - Surface Mount c/w flush adapter (Keyed / Keyless - configurable)

Custom Work: None.

Optional Items: Handrail, Fold Down Seat Kit, Platform Security Lock, In-Hanger Alarm with Battery Back-up, Auxiliary Power System, Attendant Remote Control Kit, Towers (Mild Steel).

A	INITIAL RELEASE	UNITS: INCHES	10/14/16	AU	
REV.	SCALE: NTS	TOLERANCES: DIMENSIONAL ±1/16" ANGULAR ±0.5'	PROJECTION: 	DATE	DRN.BY
		7605 - 134A STREET SURREY, BC, CANADA V3W 7B3 PH: ++1 604 594 0422 FAX: ++1 604 594 9915 http://www.garaventalift.com			29401-IG-A
		XPRESS II - iGOLDD DRAWING MURPHYS ELEMENTARY 1234 MAIN STREET MURPHYS CA			PAGE 1 OF 4
		HANKIN SPECIALTY ELEVATOR			

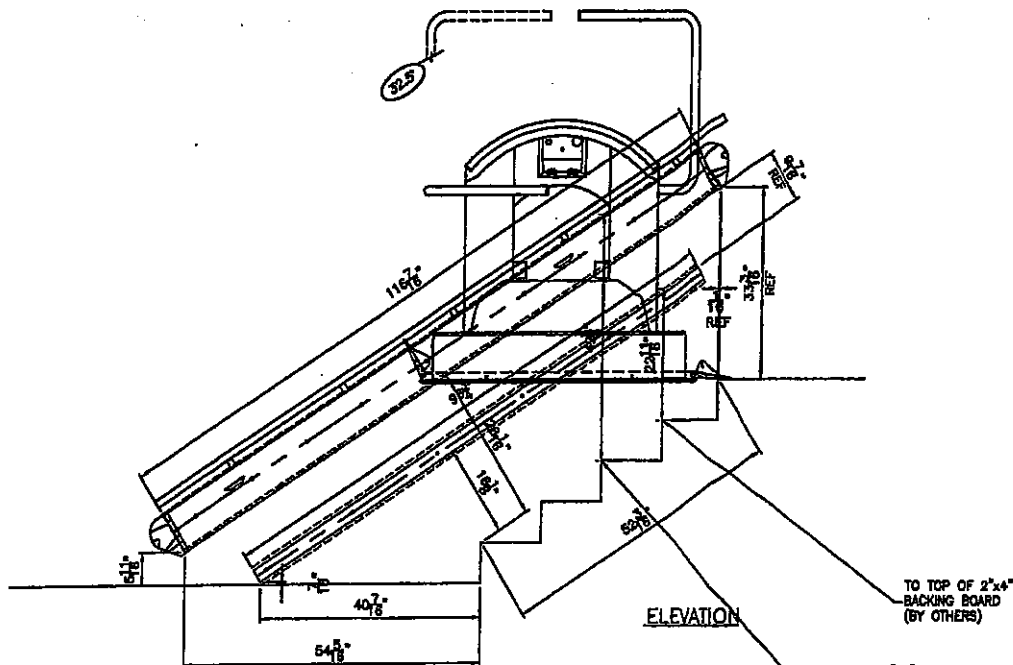

STAIR INFORMATION:
 HORIZONTAL: 44"
 VERTICAL: 28"
 SLOPE: 52 3/16°
 FIRST RISER: 7"
 UNIT SIDE: LEFT
 # OF RISERS: 5
 STAIR ANGLE: 32.5°

A INITIAL RELEASE		UNITS (BY OTHERS)		10/14/16	AU		
REV.	SCALE: NTS	TOLERANCES: DIMENSIONAL ±1/16"	ANGULAR ±0.5°	PROJECTION:	DATE	DRN.BY	CHK.BY
			7505 - 134A STREET SURREY, BC, CANADA V3W 7B3 PH: ++1 604 594 0422 FAX: ++1 604 594 9915 http://www.garaventalift.com		XPRESS II - iGOLDD DRAWING MURPHYS ELEMENTARY 1234 MAIN STREET MURPHYS CA HANKIN SPECIALTY ELEVATOR		29401-IG-A PAGE 2 OF 4

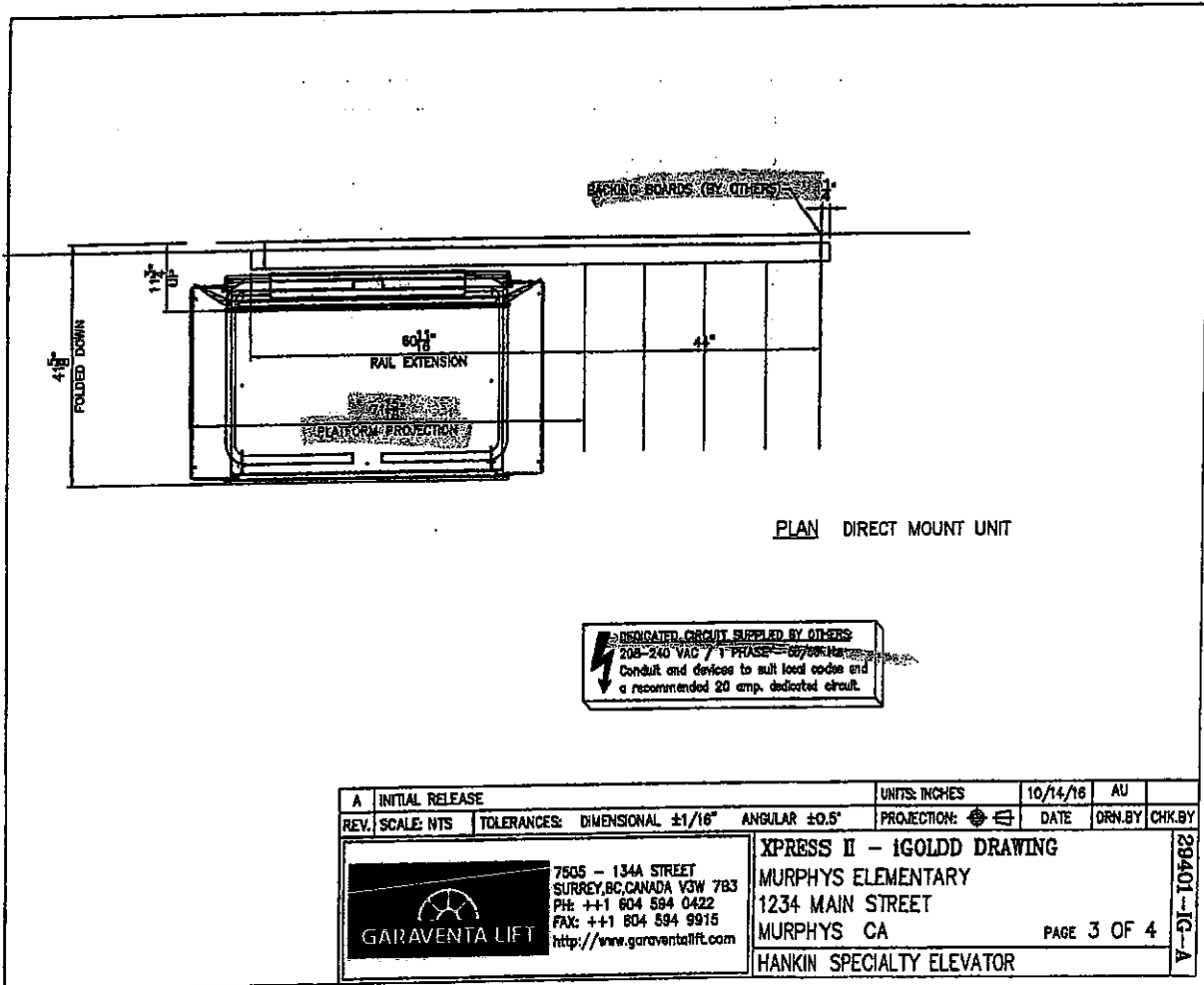

PLAN DIRECT MOUNT UNIT

⚡ DEDICATED CIRCUIT SUPPLIED BY OTHERS
 208-240 VAC 1 PHASE 60/60Hz
 Conduit and devices to suit local codes and
 a recommended 20 amp. dedicated circuit.

A	INITIAL RELEASE	UNITS: INCHES	10/14/16	AU	
REV.	SCALE: NTS	TOLERANCES: DIMENSIONAL ±1/16" ANGULAR ±0.5°	PROJECTION:	DATE	DRN. BY
		7505 - 134A STREET SURREY, BC, CANADA V3W 7B3 PH: ++1 604 594 0422 FAX: ++1 604 594 9915 http://www.garaventalift.com	XPRESS II - IGLODD DRAWING MURPHYS ELEMENTARY 1234 MAIN STREET MURPHYS CA		39401-IG-A
		HANKIN SPECIALTY ELEVATOR		PAGE 3 OF 4	

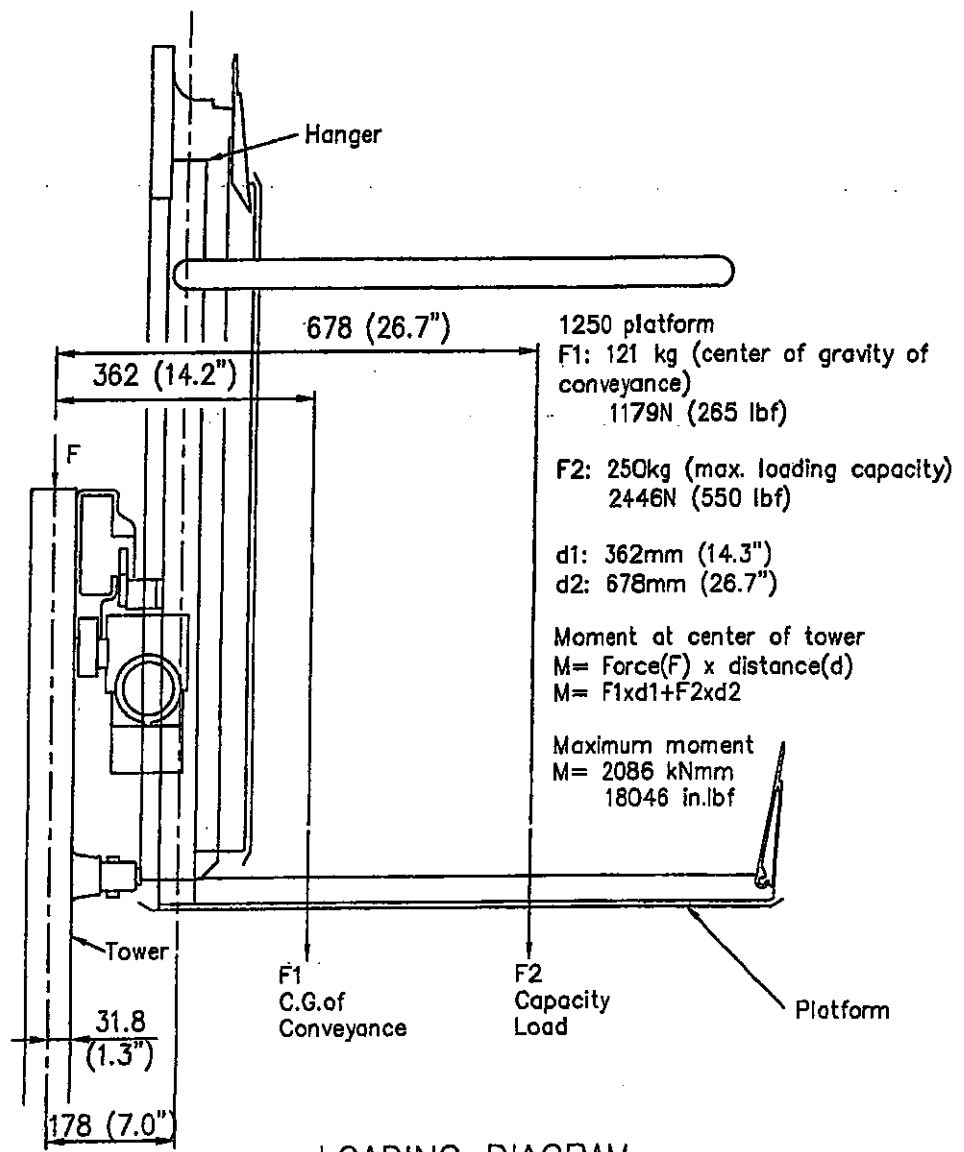

LOADING DIAGRAM
 N.T.S.

A	INITIAL RELEASE	UNITS: INCHES	10/14/16	AU		
REV.	SCALE: NTS	TOLERANCES: DIMENSIONAL $\pm 1/16"$ ANGULAR $\pm 0.5^\circ$	PROJECTION:	DATE	DRN.BY	CHK.BY
 7505 - 134A STREET SURREY, BC, CANADA V3W 7B3 PH: ++1 604 594 0422 FAX: ++1 604 594 9915 http://www.garaventalift.com		XPRESS II - iGOLDD DRAWING MURPHYS ELEMENTARY 1234 MAIN STREET MURPHYS CA HANKIN SPECIALTY ELEVATOR			29401-IG-A PAGE 4 OF 4	

Upper Rail Section Holes (mm)			
#	Sect. 1	Sect. 2	Sect. 3
1	128	0	0
2	428	0	0
3	728	0	0
4	1028	0	0
5	1328	0	0
6	1628	0	0
7	1928	0	0
8	2228	0	0
9	2528	0	0
10	2828	0	0
0	0	0	0
0	0	0	0
0	0	0	0
0	0	0	0
0	0	0	0
0	0	0	0
0	0	0	0

Lower Rail Section Holes (mm)			
#	Sect. 1	Sect. 2	Sect. 3
0	0	0	0
1	60	0	0
2	620	0	0
3	990	0	0
4	1480	0	0
5	1930	0	0
6	2400	0	0
0	0	0	0
0	0	0	0
0	0	0	0
0	0	0	0
0	0	0	0
0	0	0	0
0	0	0	0
0	0	0	0
0	0	0	0
0	0	0	0

HANDRAIL BRKT		HANDRAIL	
Bracket	Spacing	Section	
Upper	305	3129	
Typical	609	-	
Lower	388	-	

Extra Items / Options		
Description	Qty.	Material
Color	-	STANDARD
Custom Form	-	N/A
Ext. Len. Ramp	-	N/A
Ext. Up. Ramp	-	N/A
Sidewalk Ramp	-	N/A
Shims	10	N/A
Spacers	-	N/A
Spacers	-	N/A
Stringer 'M' Plates	-	N/A
Tower	-	N/A
Tower Clamp	-	N/A

X2 COMPONENT LENGTHS / LOCATIONS	
Upper Rail (overall)	= 2957
Section 1 (lwr)	= 2937
Section 2 (mid)	= 0
Section 3 (upp)	= 0
Lower Rail (overall)	= 2457
Section 1 (lwr)	= 2457
Section 2 (mid)	= 0
Section 3 (upp)	= 0
Slot Cover (overall)	= 2957
Conduit	= 1732
Cable Chain	= 1184
Cable	= 5057
Lwr. Cam Location	= 354
Upp. Cam Location	= 800
(* distance from rail end to cam center)	

A	INITIAL RELEASE	UNITS: INCHES	10/14/16	AU		
REV.	SCALE: NTS	TOLERANCES: DIMENSIONAL ±1/16" ANGULAR ±0.5°	PROJECTION:	DATE	DRN BY	CHK BY
 7505 - 134A STREET SURREY, BC, CANADA V3W 7B3 PH: ++1 604 594 0422 FAX: ++1 604 594 9915 http://www.garaventalift.com		XPRESS II -- IGOLDD DRAWING MURPHYS ELEMENTARY 1234 MAIN STREET MURPHYS CA HANKIN SPECIALTY ELEVATOR			29401-IG-A PAGE 1 OF 1	



HANKIN SPECIALTY ELEVATORS, INC

Rancho Cordova, CA 95742
Phone (916) 381-2400 Fax (916) 381-2481

Contractors License
CA / 917257

NV / 78801
NV / 78802

Roosevelt elementary, Stockton	90 degree stage lift
Sequoia Elementary, Redding	straight through stage lift
Temperance Clinton, Fresno	90 degree stage lift
Liberty Elementary, Kerman	straight through stage lift
Madison Elementary, Sanger	straight through stage lift
Academy charter, Sanger	straight through stage lift
Pixley Elementary, Pixley	straight through stage lift
Wasuma Elementary, Ahwanhee	straight through stage lift
Madera Library, Madera	straight through 9' lift
Gaston Middle School, Fresno	straight through stage lift
Univision Television Studio, Fresno	straight through stage lift
Orange Cove Middle School, orange cove	90 degree stage lift
Bullard Elementary, Fresno	straight through stage lift

To name a few.....

Steve Caldwell
Hankin Specialty
3237 Fitzgerald Road
Rancho Cordova, CA 95742
916-381-2400 office
916-381-2481 fax
916-417-9110 cell
stevec@hankinspecialty.com

INTERSTATE TRUCK CENTER



5837 N. Golden State Blvd. • Turlock, CA 95382
 Office: (209) 669-5444 Fax: (209) 669-9674
 Toll Free: (888) 684-4495



**** Reprint ****
 Invoice: **02S29329**
 Date / Hour: 11/28/2016 1:57:03PM
 Repair Order: 29329
 Customer: 83780
 Branch: 2
 Total Invoice: \$28,210.73
 Charge
 Page 1 of 3

RECEIVED
 DEC 06 2016
 BY:

Bill To: VALLECITO UNION SCHOOL
 DISTRICT
 P.O. BOX 329
 AVERY, CA 95224

Ship To: VALLECITO UNION SCHOOL
 DISTRICT
 5146 COMMERCIAL WAY
 HATHAWAY PINES, CA 95233

Work: 209-795-2293

Shop: 209-795-2293

Fax: 209-795-8505

Customer P/O: 7405 elopez fgrischott Orig R/O: 0 Completion Date: 11/2/2016

Unit Number: 12 **Model Year: 2008** **Make/Model: International RE**
Type: TRUCK **VIN: 4DRBWAAR68A648275** **Meter: 96563 Miles**
 PREFERRED CARD # 1001 0426 5399 6198

Task: 1 1212000 MISC ENGINE DIAGNOSTICS AND REPAIR. Department: Service

Complaint: CUSTOMER COMPLAINS OF EXCESSIVE ENGINE BLOW BY. CHECK AND ADVISE

Correction: FOUND COOLANT IN THE OIL. REMOVED DRAIN PLUG AND THERE WAS A LOT OF WATER THAT CAME OUT BEFORE THE OIL REMOVED THE PAN, FOUND THAT THE #2 LINER WAS SCORED AND #2 AND #6 LINERS WERE LEAKING. BEGAN ENGINE TEAR DOWN, HAD ISSUES REMOVING THE LINERS AS THEY WERE RUSTED AND STUCK IN THE BLOCK. WAS ABLE TO GET ALL OF THEM OUT WITHOUT DAMAGING THE BLOCK. COUNTERBORE AND CAM MEASUREMENTS WERE GOOD. NO BLOCK WARPAGE, REASSEMBLED ENGINE, INSTALLED ALL NEW PISTONS, LINERS, MAIN AND ROD BEARINGS, LIFTERS, PUSHRODS AND INJECTORS. ADJUSTED VALVE LASH TO SPEC. RAN ENGINE UP TO OPERATING TEMPERATURE AND NOTICED COOLANT LEAK AT THE FRONT OF THE BUS. MADE REPAIRS FOR COOLANT LEAK. ROAD TESTED BUS, IT RAN GOOD WITH NO FAULTS LOGGED.

Supp.	Part	Description / Ref Number	U/M	Quantity	Price	Extended Price
	Ssupplies	Shop Supplies		1.0	\$477.69	\$477.69
	HAZARDOUS	HAZ MAT FEE		1.0	\$144.50	\$144.50
	INCOMING	INCOMING FREIGHT		1.0	\$388.00	\$388.00
	INCOMING	INCOMING FREIGHT		1.0	\$325.00	\$325.00
	Outlabor	Outside Labor		1.0	\$525.00	\$525.00
	INCOMING	INCOMING FREIGHT		1.0	\$20.00	\$20.00
	BrakeClean	Brake Cleaner		10.0	\$2.97	\$29.70
NIPDC	2513984C91	WORKS KIT	EA	1.0	\$2,896.52	\$2,896.52
NIPDC	5010585R91	KIT TURBOCHARGER	EA	1.0	\$2,414.66	\$2,414.66
NIPDC	5010606R91	HEAD	EA	1.0	\$3,210.66	\$3,210.66
NIPDC	1875050C1	TUBE ASSY TURBO OIL INLET	EA	1.0	\$59.80	\$59.80
NIPDC	1848489C92-C	INJECTOR		6.0	\$180.00	\$1,080.00
NIPDC	1832540C94	KIT	EA	1.0	\$1,960.17	\$1,960.17
TRP	EC3501	COOLANT	EA	10.0	\$9.63	\$96.30
NIPDC	1822135C1	RING	EA	1.0	\$1.35	\$1.35
NIPDC	1842665C93	WATER PUMP KIT	EA	1.0	\$195.93	\$195.93
NIPDC	1842130C3	THERMOST	EA	1.0	\$65.60	\$65.60
NIPDC	1841923C98	ADAPTER, ASSY INJECTOR OIL INL	EA	6.0	\$26.38	\$159.28
NIPDC	1841581C1	RING	EA	1.0	\$2.89	\$2.89
NIPDC	1842563C95	OIL PUMP KIT	EA	1.0	\$635.56	\$635.56
MIS	90102	CORROSION X	EA	1.0	\$16.88	\$16.88
PB	CT05317	TIE-CABLE 50LB 15.5" BLK	EA	11.0	\$0.24	\$2.64
NIPDC	1840363C1	BOLT	EA	12.0	\$5.77	\$69.24
NIPDC	1883597C1	BOLT	EA	14.0	\$8.90	\$124.60
NIPDC	1894235C91	KIT	EA	1.0	\$1,223.59	\$1,223.59
NIPDC	1854756C1	ROD	EA	12.0	\$22.18	\$266.16
NIPDC	5010606R91-C	HEAD	EA	-1.0	\$500.00	(\$500.00)
NIPDC	1842105C1	SEAL	EA	2.0	\$3.30	\$6.60

** See Last Page for Invoice Total **

INTERSTATE TRUCK CENTER



5837 N. Golden State Blvd. • Turlock, CA 95382
 Office: (209) 669-5444 Fax: (209) 669-9674
 Toll Free: (888) 664-4495



**** Reprint ****

Invoice: **02S29329**
 Date / Hour: 11/28/2016 1:57:03PM
 Repair Order: 29329
 Customer: 83780
 Branch: 2
 Total Invoice: \$28,210.73
 Charge

Page 2 of 3

Bill To: VALLECITO UNION SCHOOL
 DISTRICT
 P.O. BOX 329
 AVERY, CA 95224

Ship To: VALLECITO UNION SCHOOL
 DISTRICT
 5146 COMMERCIAL WAY
 HATHAWAY PINES, CA 95233

Work: 209-795-2293

Shop: 209-795-2293

Fax: 209-795-8505

Customer P/O:	7405	elopez	fgrischott	Orig R/O:	0	Completion Date:	11/2/2016
NIPDC	1842106C1	SEAL		EA	1.0	\$5.82	\$5.82
PB	105FBC	GREASE-MOTOR ASSY 10 OZ L003		EA	1.0	\$5.69	\$5.69
NIPDC	2015983C1	GASKET		EA	1.0	\$15.22	\$15.22
NIPDC	1842196C96	GASKET		EA	1.0	\$487.25	\$487.25
NIPDC	1841624C1	GASKET		EA	1.0	\$32.86	\$32.86
NIPDC	1841479C1	SEAL		EA	1.0	\$12.65	\$12.65
NIPDC	1842351C1	GASKET		EA	1.0	\$7.58	\$7.58
NIPDC	1842350C1	GASKET		EA	1.0	\$12.60	\$12.60
NIPDC	1812348C1	SLEEVE		EA	4.0	\$3.47	\$13.88
NIPDC	1831826C1	GASKET		EA	1.0	\$11.97	\$11.97
NIPDC	5010585R91-C	KIT		EA	-1.0	\$350.00	(\$350.00)
NIPDC	1848489C92-C	INJECTOR		EA	-6.0	\$180.00	(\$1,080.00)
PB	CT05512	TIE-CABLE 120LB, 15.25" BLK		EA	10.0	\$0.45	\$4.50
NIPDC	1842638C92	FILTER FS19684E		EA	1.0	\$33.23	\$33.23
NIPDC	1842626C96	KIT		EA	1.0	\$84.30	\$84.30
NIPDC	1822135C1	RING		EA	1.0	\$1.35	\$1.35
FG	LF9025	FILTER-L		EA	1.0	\$41.47	\$41.47
CH	222220-463	OIL-DELO 400 LE SAE 15W40 (3		EA	8.0	\$14.12	\$112.96
Task 1 Subtotals						Parts:	\$17,208.38
						Core Chg:	\$1,930.00
						Core Ret:	(\$1,930.00)
						Labor:	\$7,225.00
						Miscellaneous:	\$1,909.89
Task 1 Subtotals							\$26,343.27

Task: 2 0909000 TEST AND INSPECT COOLING SYSTEM

Department: Service

Complaint: FOUND COOLANT LEAK AT THE FRONT OF THE BUS. CHECK AND ADVISE.

Correction: FOUND A COOLANT LEAK AT HEATER CORE HOSE AT THE FRONT OF THE BUS. REPLACED BOTH HOSES THAT GO TO THE HEATER CORE, ALSO REPLACED ALL 4 CLAMPS. RECHECKED FOR COOLANT LEAK, NO ADDITIONAL LEAKS FOUND AT THIS TIME.

Supp.	Part	Description / Ref Number	U/M	Quantity	Price	Extended Price	
	Ssupplies	Shop Supplies		1.0	\$22.31	\$22.31	
	HAZARDOUS	HAZ MAT FEE		1.0	\$6.75	\$6.75	
DC	HE5980	HOSE RAD SIL #16-2280MM W	EA	1.0	\$81.00	\$81.00	
DC	9416CMP	CLAMP-HOSE LINED 13/16X1-	EA	4.0	\$1.23	\$4.92	
Task 2 Subtotals						Parts:	\$85.92
						Labor:	\$337.50
						Miscellaneous:	\$29.06
Task 2 Subtotals							\$452.48

INTERSTATE TRUCK CENTER



5837 N. Golden State Blvd. • Turlock, CA 95382
 Office: (209) 669-5444 Fax: (209) 669-9674
 Toll Free: (888) 664-4495



**** Reprint ****
 Invoice: 02S29329
 Date / Hour: 11/28/2016 1:57:03PM
 Repair Order: 29329
 Customer: 83780
 Branch: 2
 Total Invoice: \$28,210.73
*****Charge*****
 Page 3 of 3

Bill To: VALLECITO UNION SCHOOL
 DISTRICT
 P.O. BOX 329
 AVERY, CA 95224

Ship To: VALLECITO UNION SCHOOL
 DISTRICT
 5146 COMMERCIAL WAY
 HATHAWAY PINES, CA 95233

Work: 209-795-2293

Shop: 209-795-2293

Fax: 209-795-8505

Customer P/O: 7405 elopez fgrischott Orig R/O: 0 Completion Date: 11/2/2016

Detail Tax Info:		Total Parts: \$17,294.30	
Calif Sales Tax 7.5%	\$1,391.78	Total Core Charge:	\$1,930.00
Sales Tax	\$0.00	Total Core Ret:	(\$1,930.00)
STANISLAUS SALES TAX	\$0.00	Total Labor:	\$7,562.50
STANISLAUS SALES TAX 0.125%	\$23.20	Total Miscellaneous:	\$1,938.95
Total:	\$1,414.98	Invoice Subtotal:	\$26,795.75
		Total Tax:	\$1,414.98
		Total Invoice:	\$28,210.73

Payment Method Terms Due Date
 Charge Net 30 12/28/2016

We agree to pay this invoice on or before the 10th of the month following the date of purchase. We understand that a 1.5% per month service charge is to be added to all delinquent invoices. This is an annual rate of 18%. Service charges are assessed and added to the statement and become part of the principal obligation to Interstate Truck Center/Valley Peterbilt. In the event it becomes necessary for Interstate Truck Center/Valley Peterbilt to incur any collection costs or if suit is filed to collect under this agreement, the undersigned promises to pay such additional costs of collection and costs of suit, including legal fees. Any warranties on the product sold hereby are those made by the manufacturer. The seller hereby expressly disclaims all warranties, either expressly disclaims all warranties, either express or implied, including any warranty of merchantability or fitness for a particular purpose, and the seller neither assumes nor authorizes any other person to assume for it any liability in connection with the sale of said products. Any limitation contained herein does not apply where prohibited by law. All Special order and non-stocking parts are non-refundable.

***** TO RECEIVE FULL CORE CREDIT ALL CORES MUST BE CLEAN AND DRAINED OF FLUIDS****
 *****NO RETURN ON ELECTRICAL AND SPECIAL ORDER PARTS*****
 *****ALL OTHER PARTS SUBJECT TO 20% RESTOCKING FEE*****

X _____

California School Boards Association

AGREEMENT FOR GOVERNANCE CONSULTING SERVICES

THIS Agreement made and entered into by and between the CALIFORNIA SCHOOL BOARDS ASSOCIATION, a nonprofit California corporation, hereinafter referred to as "CSBA" and Vallecito School District hereinafter referred to as "District."

CSBA agrees to provide a Governance Leadership workshop. The workshop will be completed no later than June 30, 2017.

CONDITION PRECEDENT

To be eligible for this program, the district must be a member in good standing of CSBA.

The parties hereby agree as follows:

1. DUTIES AND RESPONSIBILITIES OF DISTRICT

1.1 District agrees to:

- a. assure attendance by all board members, and the superintendent of Vallecito School District as requested by CSBA;
- b. provide appropriate facilities for each session; and
- c. provide necessary food and refreshments.

2. DUTIES, RESPONSIBILITIES AND RECOMMENDATIONS OF CSBA

2.1 CSBA agrees to:

- a. provide any necessary copyrighted course materials as needed for the Governance consulting workshop;
- b. conduct phone interviews with board members and superintendent as appropriate;
- c. perform the agreed upon Governance consulting services;
- d. provide summary materials from the Governance consulting services.

3. COMPENSATION AND OTHER EXPENSES

3.1 In consideration for the consulting services, the District agrees to pay CSBA a base fee of \$2000, plus reasonable travel expenses.

3.2 Payment is due within 30 days upon receipt of invoice from CSBA, following the service delivery.

4. CONTRACT TERMINATION

- 4.1 The terms of the Agreement shall terminate no later than June 30, 2017, or sooner if all provisions have been satisfied.
- 4.2 Unless otherwise terminated pursuant to this Agreement, CSBA or District may terminate this agreement without cause by giving thirty (30) days written notice to the other party.
- 4.3 Should CSBA default in the performance of this Agreement or materially breach any of its provisions, District may terminate this Agreement by giving written notification to CSBA.
- 4.4 Should District default in the performance of this Agreement or materially breach any of its provisions, CSBA may terminate this Agreement by giving written notification to District.

5. GENERAL PROVISIONS

- 5.1 For the purposes of communication between the parties, the following shall be the representatives of the parties:

Tom Pratt Board President	Don Ogden Superintendent	Naomi Eason, Ed.D Assistant Executive Director, Member Services
Vallecito School District P.O. Box 329 Avery, CA, 95224	Vallecito School District P.O. Box 329 Avery, CA, 95224	California School Boards Association 3251 Beacon Boulevard West Sacramento, CA 95691
Phone: 209-795-8500	Phone: 209-795-8500	Phone: (916) 669-3293 Fax: (916) 371-3407

- 5.2 This Agreement is the entire agreement and supersedes any oral or written agreements previously entered into concerning the conduct of the Governance consulting services.
- 5.3 If any provision in this Agreement is held by a court of competent jurisdiction to be invalid, void or unenforceable, the remaining provisions will nevertheless continue in full force.
- 5.4 This Agreement will be governed and construed according to the laws of the State of California.

AGREED

SCHOOL DISTRICT

BY: _____
Tom Pratt, Board President

DATED: _____

BY: _____
Don Ogden, Superintendent

DATED: 11-22-16

CALIFORNIA SCHOOL BOARDS ASSOCIATION

BY: _____
Naomi Eason, Ed.D.
Assistant Executive Director,
Member Services

DATED: 11/17/16

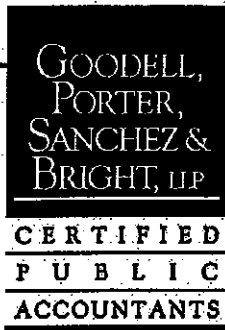

JOHN I. GOODELL, CPA
VIRGINIA K. PORTER, CPA
BEVERLY A. SANCHEZ, CPA
SUZY H. BRIGHT, CPA
RICHARD J. GOODELL, CPA
MICHELLE M. HANSON, CPA

November 17, 2016

To The Board of Trustees
Vallecito Union School District
P.O. Box 329
Avery, CA 95224

We have audited the financial statements of the governmental activities, each major fund, and the aggregate remaining fund information of Vallecito Union School District for the year ended June 30, 2016. Professional standards require that we provide you with information about our responsibilities under generally accepted auditing standards and *Government Auditing Standards*, as well as certain information related to the planned scope and timing of our audit. Professional standards also require that we advise you of the following matters relating to our audit.

Our Responsibility in Relation to the Financial Statement Audit

As communicated in our engagement letter dated March 11, 2016, our responsibility, as described by professional standards, is to form and express an opinion(s) about whether the financial statements that have been prepared by management with your oversight are presented fairly, in all material respects, in accordance with accounting principles generally accepted in the United States of America. Our audit of the financial statements does not relieve you or management of your respective responsibilities.

Our responsibility, as prescribed by professional standards, is to plan and perform our audit to obtain reasonable, rather than absolute, assurance about whether the financial statements are free of material misstatement. An audit of financial statements includes consideration of internal control over financial reporting as a basis for designing audit procedures that are appropriate in the circumstances, but not for the purpose of expressing an opinion on the effectiveness of the entity's internal control over financial reporting. Accordingly, as part of our audit, we considered the internal control of Vallecito Union School District solely for the purpose of determining our audit procedures and not to provide any assurance concerning such internal control.

We are also responsible for communicating significant matters related to the audit that are, in our professional judgment, relevant to your responsibilities in overseeing the financial reporting process. However, we are not required to design procedures for the purpose of identifying other matters to communicate to you.

Planned Scope and Timing of the Audit

We conducted our audit consistent with the planned scope and timing we previously communicated to you.

Compliance with All Ethics Requirements Regarding Independence

The engagement team, have complied with all relevant ethical requirements regarding independence. The engagement team completed the first draft of the financial statements from District books and records. The financial statement draft were reviewed with knowledgeable District management and when necessary corrections were made to the draft financial statements.

Qualitative Aspects of the Entity's Significant Accounting Practices

Significant Accounting Policies

Management has the responsibility to select and use appropriate accounting policies. A summary of the significant accounting policies adopted by Vallecito Union School District is included in Note 1 to the financial statements. There have been no initial selection of accounting policies and no changes in significant accounting policies or their application during 2015-2016. No matters have come to our attention that would require us, under professional standards, to inform you about (1) the methods used to account for significant unusual transactions and (2) the effect of significant accounting policies in controversial or emerging areas for which there is a lack of authoritative guidance or consensus.

Significant Accounting Estimates

Accounting estimates are an integral part of the financial statements prepared by management and are based on management's current judgments. Those judgments are normally based on knowledge and experience about past and current events and assumptions about future events. Certain accounting estimates are particularly sensitive because of their significance to the financial statements and because of the possibility that future events affecting them may differ markedly from management's current judgments.

The most sensitive accounting estimates affecting the financial statements were:

- The net pension liabilities for the unfunded portion of the pension plans based on actuarial projections.
- Other postemployment benefits (OPEB) expense and liability accrual based on actuarial projections.

We evaluated the key factors and assumptions used to develop the Pension Plans and OPEB Liability estimates and determined they are reasonable in relation to the basic financial statements taken as a whole and in relation to the applicable opinion units.

Financial Statement Disclosures

Certain financial statement disclosures are particularly sensitive because of their significance to financial statement users. The most sensitive disclosure affecting the District's 2015-2016 financial statements is Note 9 – Employee Retirement Systems. This note describes the liability reported on the Statement of Net Position for the District's share of unfunded STRS and PERS pension liabilities.

The disclosures in the financial statements are neutral, consistent, and clear.

Significant Difficulties Encountered during the Audit

We encountered no significant difficulties in dealing with management relating to the performance of the audit.

Uncorrected and Corrected Misstatements

For purposes of this communication, professional standards require us to accumulate all known and likely misstatements identified during the audit, other than those that we believe are trivial, and communicate them to the appropriate level of management. Further, professional standards require us to also communicate the effect of uncorrected misstatements related to prior periods on the relevant classes of transactions, account balances or disclosures, and the financial statements as a whole and each applicable opinion unit. The attached schedule summarizes uncorrected financial statement misstatements whose effects in the current and prior periods, as determined by management, are immaterial, both individually and in the aggregate, to the financial statements taken as a whole and each applicable opinion unit.

In addition, professional standards require us to communicate to you all material, corrected misstatements that were brought to the attention of management as a result of our audit procedures. The following material misstatements that we identified as a result of our audit procedures were brought to the attention of, and corrected by, management.

An adjustment of \$124,484 was made in the General Fund to reduce the recorded benefits for STRS on-behalf benefits posted by the District. Expenditures have been reduced by the same amount so the adjustment does not result in a decrease to the ending fund balance in the General Fund.

Disagreements with Management

For purposes of this letter, professional standards define a disagreement with management as a matter, whether or not resolved to our satisfaction, concerning a financial accounting, reporting, or auditing matter, which could be significant to the District's financial statements or the auditor's report. No such disagreements arose during the course of the audit.

Representations Requested from Management

We have requested certain written representations from management, which are included in the attached letter dated November 17, 2016.

Management's Consultations with Other Accountants

In some cases, management may decide to consult with other accountants about auditing and accounting matters, similar to obtaining a "second opinion" on certain situations. If a consultation involves application of an accounting principle to the District's financial statements or a determination of the type of auditor's opinion that may be expressed on those statements, our professional standards require the consulting accountant to check with us to determine that the consultant has all the relevant facts. To our knowledge, there were no such consultations with other accountants.

Other Significant Matters, Findings, or Issues

In the normal course of our professional association with Vallecito Union School District, we generally discuss a variety of matters, including the application of accounting principles and auditing standards, operating and regulatory conditions affecting the entity, and operational plans and strategies that may affect the risks of material misstatement. None of the matters discussed resulted in a condition to our retention as Vallecito Union School District's auditors.

Other Information in Documents Containing Audited Financial Statements

We were engaged to report on other supplementary information which accompany the financial statements but are not required supplementary information.

With respect to the supplementary information accompanying the financial statements, we made certain inquiries of management and evaluated the form, content, and methods of preparing the information to determine that the information complies with accounting principles generally accepted in the United States of America, the method of preparing it has not changed from the prior period, and the information is appropriate and complete in relation to our audit of the financial statements. We compared and reconciled the supplementary information to the underlying accounting records used to prepare the financial statements or to the financial statements themselves.

We applied certain limited procedures to management's discussion and analysis, budgetary comparisons and the accounting and disclosures by employer for postemployment benefits and pensions, which are required supplementary information (RSI) that supplements the basic financial statements. Our procedures consisted of inquiries of management regarding the methods of preparing the information and comparing the information for consistency with management's responses to our inquiries, the basic financial statements, and other knowledge we obtained during our audit of the basic financial statements. We did not audit the RSI and do not express an opinion or provide any assurance on the RSI.

This report is intended solely for the use of the Board of Trustees and management of Vallecito Union School District and is not intended to be and should not be used by anyone other than these specified parties.

Very truly yours,

GOODELL, PORTER, SANCHEZ & BRIGHT, LLP

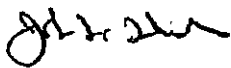

John L. Goodell
Certified Public Accountant

JLG;jn

Vallecito Union School District
 Schedule of Unrecorded Adjustments
 As of and for the Year Ended June 30, 2016

The following items represent potential adjustments that were not recorded as adjustments to the financial statements because they are considered immaterial both individually and in the aggregate.

<u>Fund</u>	<u>Debit</u>	<u>Credit</u>
General Fund- Contract Services	\$12,317	
General Fund- Accounts Payable		\$12,317
<i>To record accrual of 2015-16 bill from CCOE charged to 2016-17 by the District</i>		
General Fund- Investments	\$22	
General Fund- Interest Income		\$22
<i>To record interest on Charles Schwab account</i>		
Cafeteria Fund- Other Local Revenue	\$40	
Cafeteria Fund- Cash on Hand in Bank		\$40
<i>To adjust Clearing account to actual</i>		

We did not adjust the amount reported for Cash in County Treasury at June 30, 2016 to the current fair value amount. Had we recorded the adjustment, the District's total amount reported as Cash in County Treasury would increase \$19,305.



VALLECITO UNION SCHOOL DISTRICT

P. O. Box 329 – Avery, CA 95224
Phone (209) 795-8500, Fax (209) 795-8505
vallecito-ca.schoolloop.com

November 17, 2016

Goodell, Porter, Sanchez & Bright, LLP
7801 Folsom Blvd. #301
Sacramento, CA 95826

This representation letter is provided in connection with your audit of the financial statements of Vallecito Union School District, which comprise the respective financial position of the governmental activities, each major fund, and the aggregate remaining fund information as of June 30, 2016, and the respective changes in financial position and, where applicable, cash flows for the year then ended, and the related notes to the financial statements, for the purpose of expressing opinions as to whether the financial statements are presented fairly, in all material respects, in accordance with accounting principles generally accepted in the United States of America (U.S. GAAP).

Certain representations in this letter are described as being limited to matters that are material. Items are considered material, regardless of size, if they involve an omission or misstatement of accounting information that, in light of surrounding circumstances, makes it probable that the judgment of a reasonable person relying on the information would be changed or influenced by the omission or misstatement.

We confirm, to the best of our knowledge and belief, having made such inquiries as we considered necessary for the purpose of appropriately informing ourselves as of November 17, 2016.

Financial Statements

1. We have fulfilled our responsibilities, as set out in the terms of the audit engagement letter dated March 11, 2016, including our responsibility for the preparation and fair presentation of the financial statements and for preparation of the supplementary information in accordance with the applicable criteria.
2. The financial statements referred to above are fairly presented in conformity with U.S. GAAP and include all properly classified funds and other financial information of the primary government and all component units required by generally accepted accounting principles to be included in the financial reporting entity.
3. We acknowledge our responsibility for the design, implementation, and maintenance of internal control relevant to the preparation and fair presentation of financial statements that are free from material misstatement, whether due to fraud or error.
4. We acknowledge our responsibility for the design, implementation, and maintenance of internal control to prevent and detect fraud.
5. Significant assumptions we used in making accounting estimates, including those measured at fair value, are reasonable.
6. Related party relationships and transactions have been appropriately accounted for and disclosed in accordance with the requirements of U.S. GAAP.
7. All events subsequent to the date of the financial statements and for which U.S. GAAP requires adjustment or disclosure have been adjusted or disclosed.

8. The effects of uncorrected misstatements are immaterial, both individually and in the aggregate, to the financial statements for each opinion unit. A list of the uncorrected misstatements is attached to the representation letter.
9. The effects of all known actual or possible litigation, claims, and assessments have been accounted for and disclosed in accordance with U.S. GAAP.
10. Guarantees, whether written or oral, under which the Vallecito Union School District is contingently liable, if any, have been properly recorded or disclosed.

Information Provided

11. We have provided you with:
 - a. Access to all information, of which we are aware, that is relevant to the preparation and fair presentation of the financial statements, such as records, documentation, and other matters and all audit or relevant monitoring reports, if any, received from funding sources.
 - b. Additional information that you have requested from us for the purpose of the audit.
 - c. Unrestricted access to persons within the entity from whom you determined it necessary to obtain audit evidence.
 - d. Minutes of the meetings of the Governing Board or summaries of actions of recent meetings for which minutes have not yet been prepared.
12. All transactions have been recorded in the accounting records and are reflected in the financial statements and the schedule of expenditures of federal awards.
13. We have disclosed to you the results of our assessment of the risk that the financial statements may be materially misstated as a result of fraud.
14. We have no knowledge of any fraud or suspected fraud that affects the entity and involves:
 - Management,
 - Employees who have significant roles in internal control, or
 - Others where the fraud could have a material effect on the financial statements.
15. We have no knowledge of any allegations of fraud or suspected fraud affecting the entity's financial statements communicated by employees, former employees, regulators, or others.
16. We have no knowledge of instances of noncompliance or suspected noncompliance with provisions of laws, regulations, contracts, or grant agreements, or abuse, whose effects should be considered when preparing financial statements.
17. We have disclosed to you all known actual or possible litigation, claims, and assessments whose effects should be considered when preparing the financial statements.
18. We have disclosed to you the identity of the entity's related parties and all the related party relationships and transactions of which we are aware.

Government-Specific

19. There have been no communications from regulatory agencies concerning noncompliance with, or deficiencies in, financial reporting practices.
20. We have a process to track the status of audit findings and recommendations.
21. We have identified to you any previous audits, attestation engagements, and other studies related to the audit objective and whether related recommendations have been implemented.
22. We have provided our views on reported findings, conclusions, and recommendations, as well as our planned corrective actions, for the report.
23. The Vallecito Union School District has no plans or intentions that may materially affect the carrying value or classification of assets, liabilities, or equity.
24. We are responsible for compliance with the laws, regulations, and provisions of contracts and grant agreements applicable to us, including tax or debt limits and debt contracts and legal and contractual provisions for reporting specific activities in separate funds.
25. We have identified and disclosed to you all instances that have occurred or are likely to have occurred, of fraud and noncompliance with provisions of laws and regulations that we believe have a material effect on the financial statements or other financial data significant to the audit objectives, and any other instances that warrant the attention of those charged with governance.
26. We have disclosed to you all significant estimates and material concentrations known to management that are required to be disclosed. Significant estimates are estimates at the balance sheet date that could change materially within the next year. Concentrations refer to volumes of business, revenues, available sources of supply, or markets or geographic areas for which events could occur that would significantly disrupt normal finances within the next year.
27. We have identified and disclosed to you all instances, which have occurred or are likely to have occurred, of noncompliance with provisions of contracts and grant agreements that we believe have a material effect on the determination of financial statement amounts or other financial data significant to the audit objectives.
28. We have identified and disclosed to you all instances that have occurred or are likely to have occurred, of abuse that could be quantitatively or qualitatively material to the financial statements or other financial data significant to the audit objectives.
29. There are no violations or possible violations of budget ordinances, laws and regulations (including those pertaining to adopting, approving, and amending budgets), provisions of contract and grant agreements, tax or debt limits, and any related debt covenants whose effects should be considered for disclosure in the financial statements, or as a basis for recording a loss contingency, or for reporting on noncompliance.
30. As part of your audit, you assisted with preparation of the financial statements and related notes. We acknowledge our responsibility as it relates to those nonaudit services, including that we assume all management responsibilities; oversee the services by designating an individual preferably within senior management, who possesses suitable skill, knowledge, or experience; evaluate the adequacy and results of the services performed; and accept responsibility for the results of the services. We have reviewed, approved, and accepted responsibility for those financial statements and related notes.
31. The Vallecito Union School District has satisfactory title to all owned assets, and there are no liens or encumbrances on such assets nor has any asset been pledged as collateral.
32. The Vallecito Union School District has complied with all aspects of contractual agreements that would have a material effect on the financial statements in the event of noncompliance.

33. The financial statements include all component units as well as joint ventures with an equity interest, and properly disclose all other joint ventures and other related organizations.
34. The financial statements properly classify all funds and activities in accordance with GASB Statement No. 34.
35. All funds that meet the quantitative criteria in GASB Statement Nos. 34 and 37 for presentation as major are identified and presented as such and all other funds that are presented as major are particularly important to financial users.
36. Components of net position (net investment in capital assets, restricted, and unrestricted) and components of fund balance (nonspendable, restricted, committed, assigned and unassigned) are properly classified and, if applicable, approved.
37. With regard to investments and other instruments reported at fair value:
 - The underlying assumptions are reasonable and they appropriately reflect management's intent and ability to carry out its stated courses of action.
 - The measurement methods and related assumptions used in determining fair value are appropriate in the circumstances and have been consistently applied.
 - The disclosures related to fair values are complete, adequate, and in accordance with U.S. GAAP.
 - There are no subsequent events that require adjustments to the fair value measurements and disclosures included in the financial statements.
38. Expenses have been appropriately classified in or allocated to functions and programs in the statement of activities, and allocations have been made on a reasonable basis.
39. Revenues are appropriately classified in the statements of activities within program revenues, general revenues, contributions to term or permanent endowments, or contributions to permanent fund principal.
40. Interfund, internal, and intra-entity activity and balances have been appropriately classified and reported.
41. Deposits and investment securities and derivative transactions are properly classified as to risk and are properly disclosed.
42. Capital assets, including infrastructure and intangible assets, are properly capitalized, reported, and, if applicable, depreciated.
43. We have appropriately disclosed the Vallecito Union School District's policy regarding whether to first apply restricted or unrestricted resources when an expense is incurred for purposes for which both restricted and unrestricted net position are available and have determined that net position was properly recognized under the policy.
44. We are following our established accounting policy regarding which resources (that is, restricted, committed, assigned, or unassigned) are considered to be spent first for expenditures for which more than one resource classification is available. That policy determines the fund balance classifications for financial reporting purposes.
45. We acknowledge our responsibility for the required supplementary information (RSI). The RSI is measured and presented within prescribed guidelines and the methods of measurement and presentation have not changed from those used in the prior period. We have disclosed to you any significant assumptions and interpretations underlying the measurement and presentation of the RSI.

46. With respect to the supplementary information:

- a. We acknowledge our responsibility for presenting the supplementary information. In accordance with accounting principles generally accepted in the United States of America, and we believe the supplementary information, including its form and content, is fairly presented in accordance with accounting principles generally accepted in the United States of America. The methods of measurement and presentation of the supplementary information have not changed from those used in the prior period, and we have disclosed to you any significant assumptions or interpretations underlying the measurement and presentation of the supplementary information.
- b. If the supplementary information is not presented with the audited financial statements, we will make the audited financial statements readily available to the intended users of the supplementary information and the auditor's report thereon.

Signed:

Title:

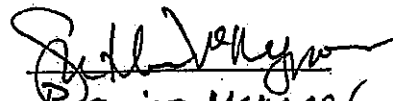
Business Manager

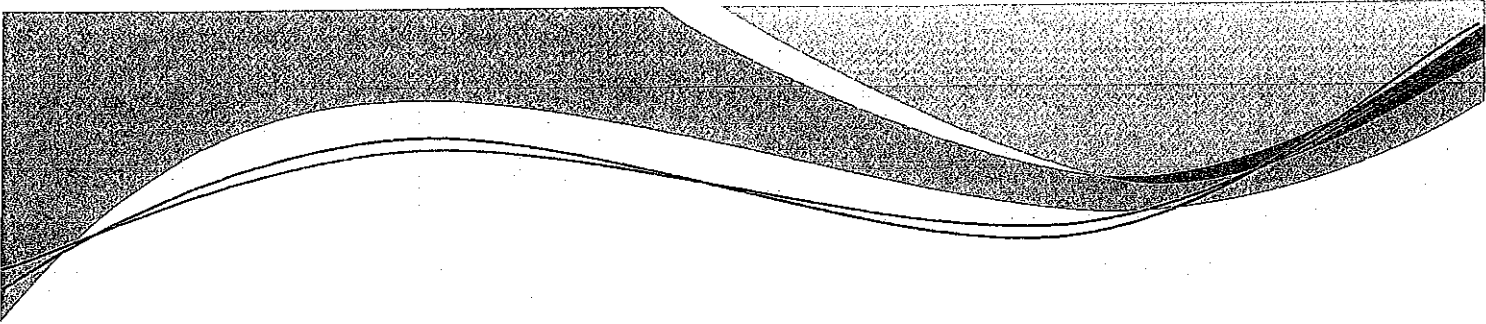

All School Board Members, Superintendents, Elected
Board of Supervisors, City Council and
external Partners
of
Calaveras County

You're Presence is requested.

The Rural County School Board Association

**Would like to have Courageous Conversations
about Cannabis and our Students.
This is a non Political Event.**

January 11, 2017

5:30 p.m.

Bret Harte High School

Please RSVP to Sherri Reusche
(209) 986-3413 or
jsreusche@comcast.net

no later than January 6, 2017

products and services Offerings for governance teams, school districts and county offices of education

Product Summary

Shop (../CSBAStore.aspx)

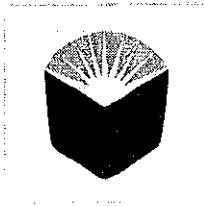

2017 Brown Act (1/27/17- Sacramento)

List Price: \$185.00

Login to Continue

Description

Register now online, or by downloading the [registration form](https://www.csba.org/~media/CSBA/Files/trainingandevents/regforms/generalregform.ashx) (<https://www.csba.org/~media/CSBA/Files/trainingandevents/regforms/generalregform.ashx>).

Brown Act: Sacramento - What You Need to Know Board members, board presidents, superintendents and executive assistants often have questions about the Brown Act and its guidelines for open meetings. Attend this interactive evening session and find out everything you need to know and more about this complex act including how to apply the law. Don't let this opportunity pass you by. LOCATION: Hyatt Regency Sacramento 1209 L Street Sacramento, CA 95814 (916) 443-1234 Schedule: Registration opens at 5:00 p.m.; workshop is 5:30 – 8:30 p.m. Registration fee: Early registration: \$185/ Onsite registration: \$210 (Fee includes materials and refreshments) HOTEL INFORMATION: Hyatt Regency Sacramento Hotel Please make your reservations directly with Hyatt Regency Hotel; the rate is \$165 single/double. Please make your reservation early. Your accommodation can be secured at the special group rate if rooms are still available in the block of rooms that CSBA has negotiated. After the January 5, 2017 cut-off date, rooms will provided on a space-available basis only and the special group rate may not be available.



California County Boards of Education
California Council of School Attorneys
Education Legal Alliance
National School Boards Association
The Center for Public Education

[Privacy Policy](#) | [Legal Notice](#) | [Careers](#) | [Contact Us](#)

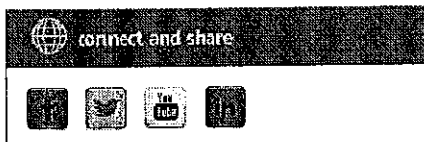

- about
 - How We are Governed
 - Board of Directors
 - Executive Staff
 - Staff Directory
- products & services
 - All Products and Services
 - Agenda Online
 - Gamut Online
 - Practical
- advocacy
 - Legislative Advocacy
 - Legislative News
 - Legal Advocacy
 - Stand Up 4 Public Schools
- governance & policy resources
 - District Policy Services
 - Policy News and Briefs
 - LCFF & LCAP
 - Golden Bell Awards program
 - Governance Briefs
- training & events
 - Event Calendar
 - All Events
 - Masters in Governance Program
 - Annual Education Conference
- newsroom
 - Advertising Opportunities
 - California Schools Magazine
 - CSBA Newsletters